

SF SUNTOUR

SF11-XCM-V3-DS-PM-MLO-29"

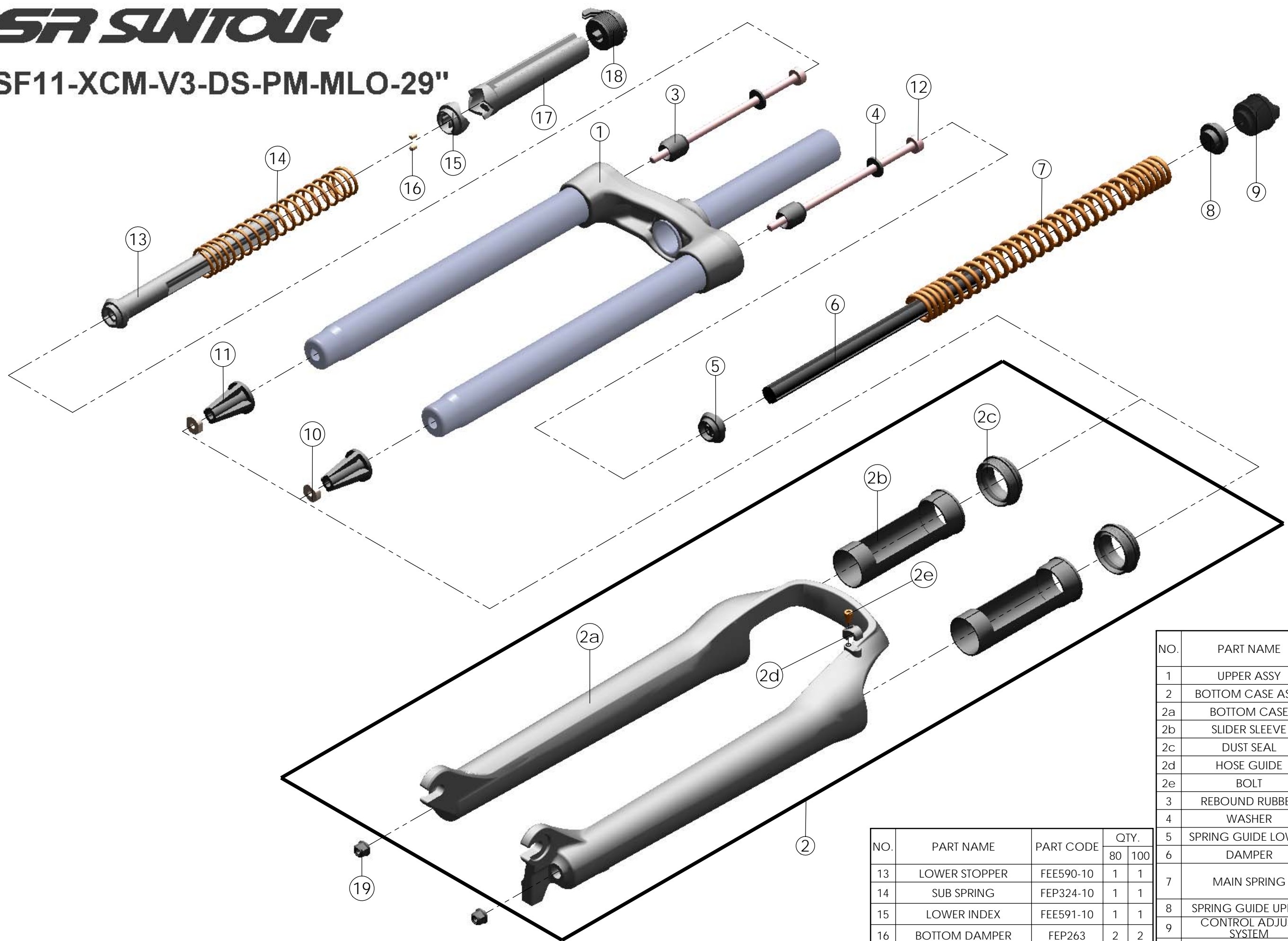

NO.	PART NAME	PART CODE	QTY.	
			80	100
1	UPPER ASSY	FKE356-60	1	1
2	BOTTOM CASE ASSY	FKE366	1	1
2a	BOTTOM CASE	FPB281	1	1
2b	SLIDER SLEEVE	FEE785	2	2
2c	DUST SEAL	FAA070-20	2	2
2d	HOSE GUIDE	FEE797	1	1
2e	BOLT	FSB153	1	1
3	REBOUND RUBBER	FEP086	2	2
4	WASHER	FSW003	2	2
5	SPRING GUIDE LOWER	FEE593-10	1	1
6	DAMPER	FEP322-10	1	1
7	MAIN SPRING	FEP326	1	-
		FEP323	-	1
8	SPRING GUIDE UPPER	FEE592-10	1	1
9	CONTROL ADJUST SYSTEM	FKE009-11	1	1
10	NUT PLATE	FSN025	2	2
11	BOTTOM STOPPER	FEE958-00	2	2
12	FIXING BOLT	FSB109-70	2	-
		FSB109-71	-	2
13	LOWER STOPPER	FEE590-10	1	1
14	SUB SPRING	FEP324-10	1	1
15	LOWER INDEX	FEE591-10	1	1
16	BOTTOM DAMPER	FEP263	2	2
17	UPPER STOPPER	FEE589-10	1	1
18	MLO TOP CAP ASSY	FKE078-12	1	1
19	FIXING NUT	FSN023	2	2

NO.	PART NAME	PART CODE	QTY.	
			80	100
1	UPPER ASSY	FKE356-60	1	1
2	BOTTOM CASE ASSY	FKE366	1	1
2a	BOTTOM CASE	FPB281	1	1
2b	SLIDER SLEEVE	FEE785	2	2
2c	DUST SEAL	FAA070-20	2	2
2d	HOSE GUIDE	FEE797	1	1
2e	BOLT	FSB153	1	1
3	REBOUND RUBBER	FEP086	2	2
4	WASHER	FSW003	2	2
5	SPRING GUIDE LOWER	FEE593-10	1	1
6	DAMPER	FEP322-10	1	1
7	MAIN SPRING	FEP326	1	-
		FEP323	-	1
8	SPRING GUIDE UPPER	FEE592-10	1	1
9	CONTROL ADJUST SYSTEM	FKE009-11	1	1
10	NUT PLATE	FSN025	2	2
11	BOTTOM STOPPER	FEE958-00	2	2
12	FIXING BOLT	FSB109-70	2	-
		FSB109-71	-	2