

SUNTOUR

SF11-XCT-V3-DS-26"-100

Date	2010.2.4	Version	1
Amended			

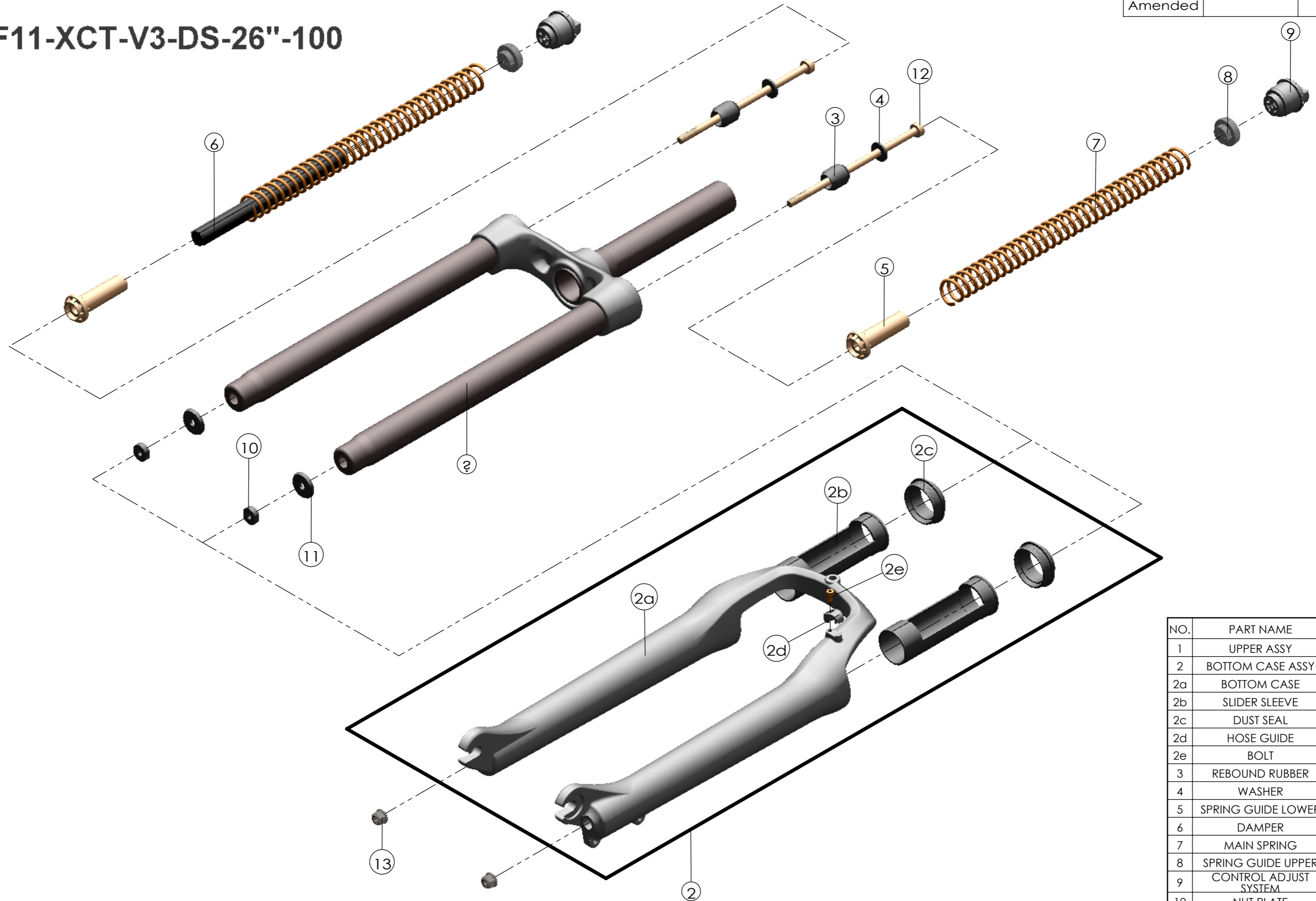

NO.	PART NAME	PART CODE	QTY.
1	UPPER ASSY	FKE351-10	1
2	BOTTOM CASE ASSY	FKE353	1
2a	BOTTOM CASE	FPB278	1
2b	SLIDER SLEEVE	FEE942	2
2c	DUST SEAL	FAA125-40	2
2d	HOSE GUIDE	FEE797	1
2e	BOLT	FSB153	1
3	REBOUND RUBBER	FEP086-10	2
4	WASHER	FSW003	2
5	SPRING GUIDE LOWER	FEE502-30	2
6	DAMPER	FEP262-20	1
7	MAIN SPRING	FEP400	2
8	SPRING GUIDE UPPER	FEE389-40	2
9	CONTROL ADJUST SYSTEM	FKE008-11	2
10	NUT PLATE	FSN025	2
11	BOTTOM STOPPER	FEE465	2
12	FIXING BOLT	FSB067-70	2
13	FIXING NUT	FSN023	2