

Date	2013.10.8	Version	1
Amended			

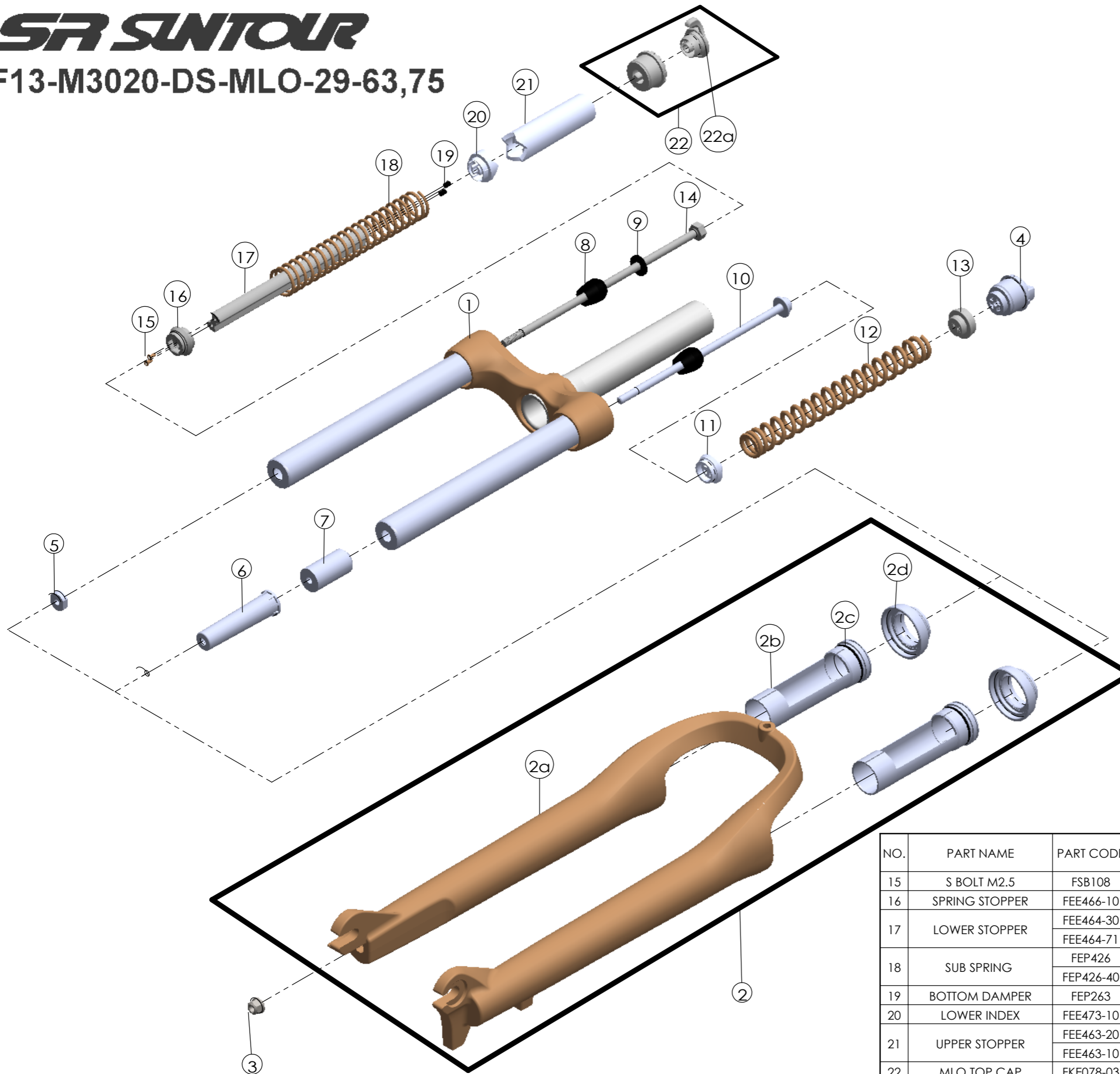

NO.	PART NAME	PART CODE	QTY.	
			63	75
15	S BOLT M2.5	FSB108	2	2
16	SPRING STOPPER	FEE466-10	1	1
17	LOWER STOPPER	FEE464-30	1	-
		FEE464-71	-	1
18	SUB SPRING	FEP426	1	-
		FEP426-40	-	1
19	BOTTOM DAMPER	FEP263	2	2
20	LOWER INDEX	FEE473-10	1	1
21	UPPER STOPPER	FEE463-20	1	-
		FEE463-10	-	1
		FEE463-10	-	1
22	MLO TOP CAP	FKE078-03	1	1
22a	MLO KNOB	FEE493-10	1	1

NO.	PART NAME	PART CODE	QTY.	
			63	75
1	UPPER ASSY	FKZ016-02	1	1
2	BOTTOM CASE ASSY	FKZ018-20	1	1
2a	BOTTOM CASE	FPB345-10	1	1
2b	SLIDER SLEEVE	FEE789	2	2
2c	DUST SEAL	FAA192	2	2
2d	DUST BOOTS	FAA129	2	2
3	FIXING NUT	FSN023	1	1
4	ADJUST SYSTEM	FKE008-11	1	1
5	NUT PLATE	FSN025	1	1
6	BOTTOM STOPPER	FEG045	1	1
7	DAMPER	FEP065-08	1	1
8	REBOUND RUBBER	FEP086-10	2	2
9	WASHER	SW003	1	1
10	FIXING NUT L	FSB171-03	1	-
		FSB171-07	-	1
11	SPRING GUIDE	FEE468-10	1	1
12	MAIN SPRING	FEP691	1	-
		FEP690	-	1
13	SPRING GUIDE	FEE467-10	1	1
14	FIXING NUT R	FSB109-61	1	-
		FSB109-67	-	1