

Date	2012.4.14	Version	1
Amended			

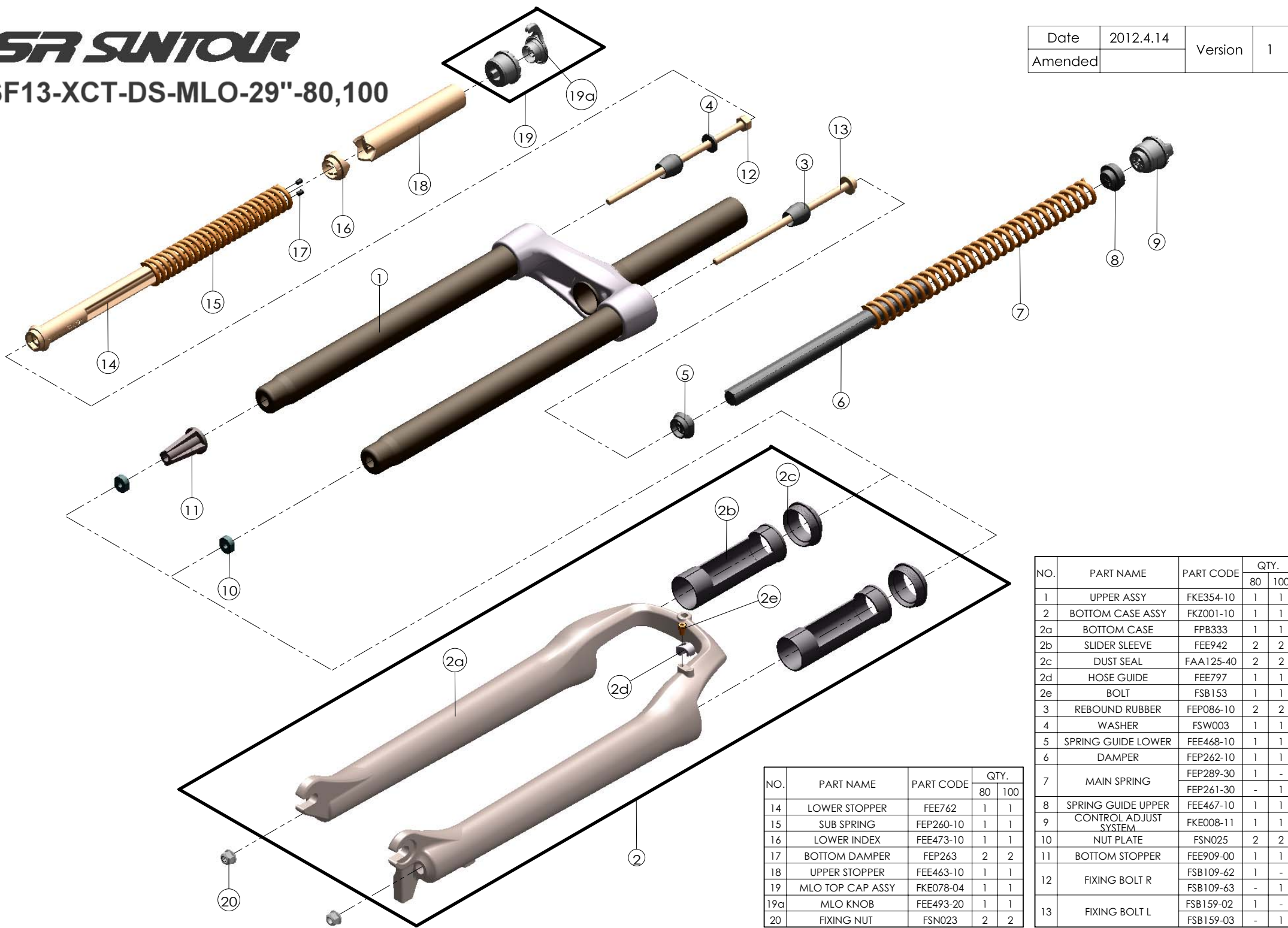

NO.	PART NAME	PART CODE	QTY.	
			80	100
1	UPPER ASSY	FKE354-10	1	1
2	BOTTOM CASE ASSY	FKZ001-10	1	1
2a	BOTTOM CASE	FPB333	1	1
2b	SLIDER SLEEVE	FEE942	2	2
2c	DUST SEAL	FAA125-40	2	2
2d	HOSE GUIDE	FEE797	1	1
2e	BOLT	FSB153	1	1
3	REBOUND RUBBER	FEP086-10	2	2
4	WASHER	FSW003	1	1
5	SPRING GUIDE LOWER	FEE468-10	1	1
6	DAMPER	FEP262-10	1	1
7	MAIN SPRING	FEP289-30	1	-
		FEP261-30	-	1
8	SPRING GUIDE UPPER	FEE467-10	1	1
9	CONTROL ADJUST SYSTEM	FKE008-11	1	1
10	NUT PLATE	FSN025	2	2
11	BOTTOM STOPPER	FEE909-00	1	1
12	FIXING BOLT R	FSB109-62	1	-
		FSB109-63	-	1
13	FIXING BOLT L	FSB159-02	1	-
		FSB159-03	-	1

NO.	PART NAME	PART CODE	QTY.	
			80	100
14	LOWER STOPPER	FEE762	1	1
15	SUB SPRING	FEP260-10	1	1
16	LOWER INDEX	FEE473-10	1	1
17	BOTTOM DAMPER	FEP263	2	2
18	UPPER STOPPER	FEE463-10	1	1
19	MLO TOP CAP ASSY	FKE078-04	1	1
19a	MLO KNOB	FEE493-20	1	1
20	FIXING NUT	FSN023	2	2