

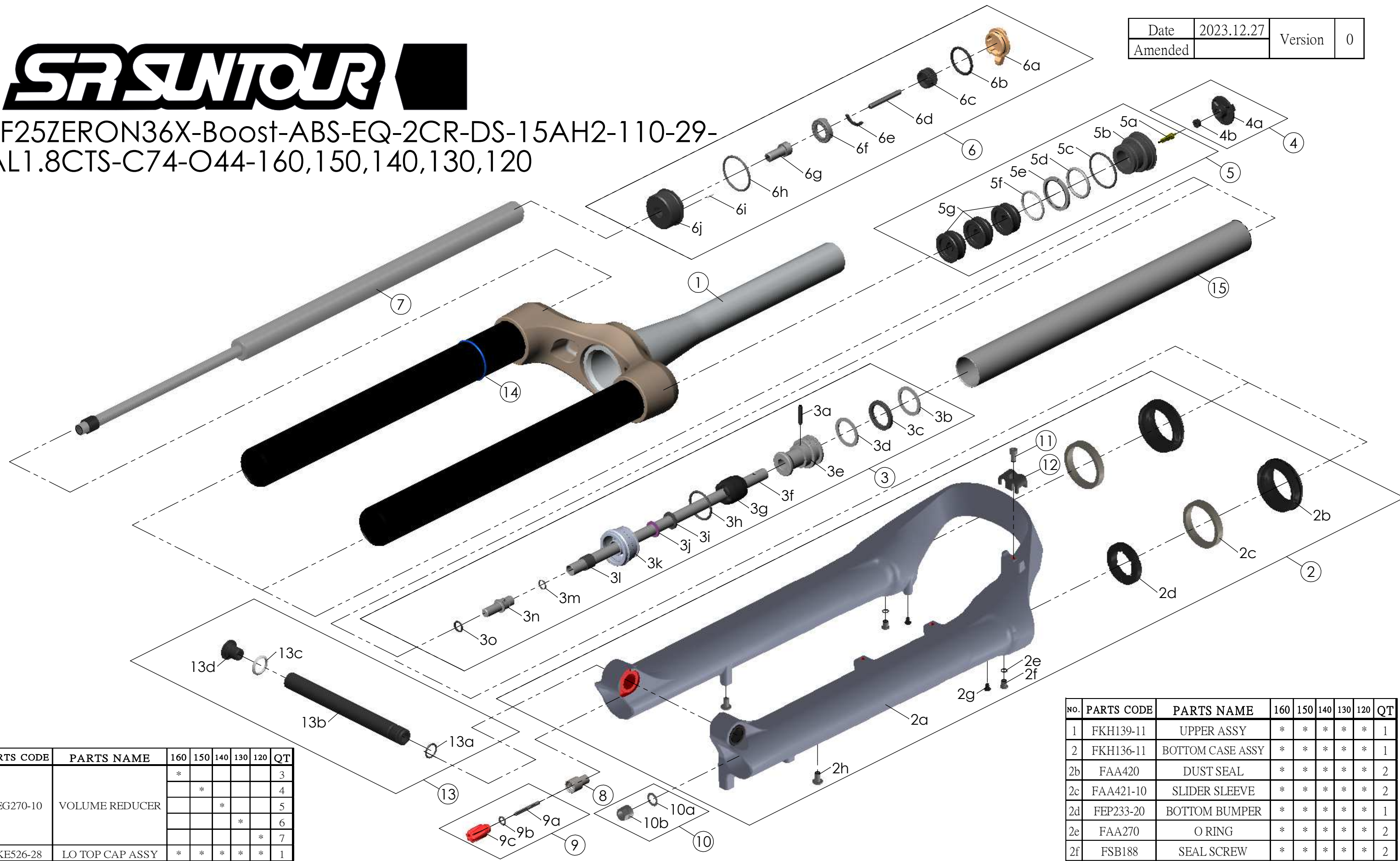

SF25ZERON36X-Boost-ABS-EQ-2CR-DS-15AH2-110-29-
AL1.8CTS-C74-O44-160,150,140,130,120

Date	2023.12.27	Version	0
Amended			



NO.	PARTS CODE	PARTS NAME	160	150	140	130	120	QT
1	FKH139-11	UPPER ASSY	*	*	*	*	*	1
2	FKH136-11	BOTTOM CASE ASSY	*	*	*	*	*	1
2b	FAA420	DUST SEAL	*	*	*	*	*	2
2c	FAA421-10	SLIDER SLEEVE	*	*	*	*	*	2
2d	FEP233-20	BOTTOM BUMPER	*	*	*	*	*	1
2e	FAA270	O RING	*	*	*	*	*	2
2f	FSB188	SEAL SCREW	*	*	*	*	*	2
2g	FAA200-10	MOUNT CAP	*	*	*	*	*	2
2h	FSB203	FIXING BOLT	*	*	*	*	*	2
3	FKH154-00	AIR CYLINDER ASSY	*					1
	FKH154-01			*				
	FKH154-02				*			
	FKH154-03					*		
	FKH154-04					*		

NO.	PARTS CODE	PARTS NAME	160	150	140	130	120	QT
	FPE002-80	SUPPORT TUBE	*					1
	FPE002-81			*				1
	FPE002-82				*			1
	FPE002-83					*		1
	FPE002-84						*	1
4	FKE595	VALVE CAP ASSY	*	*	*	*	*	1

NO.	PARTS CODE	PARTS NAME	160	150	140	130	120	QT
5	FKE594	AIR CAP ASSY	*					1
	FKE594-10			*				
	FKE594-20				*			
	FKE594-30					*		
	FKE594-40						*	

NO.	PARTS CODE	PARTS NAME	160	150	140	130	120	QT
5g	FEG270-10	VOLUME REDUCER	*					3
				*				4
					*			5
						*		6
							*	7
6	FKE526-28	LO TOP CAP ASSY	*	*	*	*	*	1
7	FUN200-65	LOR UNIT	*	*	*	*	*	1
8	FSB058	DAMPER FIXING BOLT	*	*	*	*	*	1
9	FKA004-22	DAMPER KNOB ASSY	*	*	*	*	*	1
10	FKA063-03	FIXING NUT SET	*	*	*	*	*	1
11	FSB153	GUIDE FIXING BOLT	*	*	*	*	*	1
12	FEG519	CABLE GUIDE	*	*	*	*	*	1
13	FKA117-00	15AH2-110 THRU AXLE SET	*	*	*	*	*	1
14	FAA397-40	O RING	*	*	*	*	*	1
15	FPE099-00	Air Cylinder	*	*	*	*	*	1