

ENGLISH



A  
U  
R  
O  
N  
3  
6

**SUNTOUR**



# CONTENT

## 2K25 HIGHLIGHTS / TECHNOLOGY & FEATURES

---

<u>AURON36 SERIES INTRODUCTION</u>	05
<u>SOBA</u>	06
<u>EQ SYSTEM KEY</u>	07
<u>SPECIFICATIONS THRU</u>	08
<u>AXLE INSTALLATION</u>	11
<u>TERMS AND SETUP</u>	12
<u>SAG AND AIR PRESSURE SETTING</u>	13
<u>REBOUND SETTING</u>	14
<u>AIR VOLUME SETTING</u>	16
<u>COMPRESSION ADJUSTMENT</u>	17
<u>QUICK SERVICE PORTS (QSP)</u>	18
<u>SERVICE INTERVALS</u>	19
<u>GUIDE SERVICES</u>	19
<u>GUIDES DISCLAIMER /SAFETY</u>	20
<u>LOWER LEGS SERVICE</u>	28
<u>AIR CHAMBER SERVICE</u>	41
<u>TRAVEL CONVERSION</u>	52
<u>CARTRIDGE REPLACEMENT</u>	55
<u>SPECIFICATIONS</u>	58
<u>SOCIAL MEDIA / GLOBAL CONTACTS</u>	59

## WARNING

Carefully read, understand and follow the instructions provided in this manual, and keep it in a safe place for future reference. If you have any doubt whatsoever regarding the use or maintenance of any SR SUNTOUR product, please contact SR SUNTOUR. Failure to follow these warnings and instructions can result in product malfunction, causing an accident, severe injury or death.

## IMPORTANT SAFETY INFORMATION

- Read this manual thoroughly before using your suspension system.
- These instructions contain important information about the correct installation, service and maintenance of your suspension fork. Common mechanical knowledge may not be sufficient. Your suspension fork should be only be installed, serviced and/or maintained by a trained and qualified bicycle mechanic with specialized tools.
- Our suspension systems contain fluids and gases under extreme pressure. Never try to open any SR SUNTOUR suspension system! Pieces can be violently ejected.
- SR SUNTOUR suspension forks are designed as a single integrated system. To avoid product malfunction and an accident, use only genuine SR SUNTOUR spare parts. The use of third-party supplier spare parts also voids the warranty of your suspension system.
- Your suspension fork is not intended for jumps, aggressive downhill rides, freeride or dirt jumping if the warning sticker on your suspension system prohibits these activities. Disregarding these instructions may cause your suspension fork to fail, resulting in an accident, personal injury or death, and will void the warranty.

## WARNING

- SR SUNTOUR suspension fork is designed for use by a single rider.
- Select the correct suspension fork according to your frame's dimensions and your personal riding style. Installing a suspension for which does not match the geometry of your frame could result into a failure of the suspension fork or frame could result into a failure of the suspension fork or frame itself and will void the shocks warranty. Failure of the suspension fork or frame itself and will void the shocks warranty.
- Know the limits of your skill and experience, and never ride beyond them.
  - Read, understand and follow all owner's manuals provided with your bike and all of its components.
- Always be equipped with proper safety gear. This includes a properly fitted and fastened helmet.

## BEFORE EVERY RIDE

- Inspect your bicycle and suspension system including the handlebars, pedals, crank arms, seat post, saddle, etc. For any cracks, dents, bent or tarnished parts, Also search for any oil leaking out of your shocks. Be sure to check hidden areas on the underside of your bike. If any condition exists, consult a trained and qualified bicycle mechanic to determine the cause and make any necessary correction.
- Compress your suspension system with your body weight. If it feels too soft, make the necessary adjustments until you have reached the correct SAG value. Please also see the instruction in this manual regarding SAG.
- Make sure your brakes are properly installed/adjusted and work correctly.
- Spin the wheels. Make sure that wheels are perfectly centered and do not contact the suspension fork or brakes.
- If you are using a quick release system to fasten your wheel set, make sure that all levers and nuts are properly tightened. In case you are using a through axle system, make sure that all fixing bolts are tightened with the appropriate torque values. Strictly follow the instructions provided by the manufacturer of the quick release or through axle system.



## AURON36 TAME ANY TRAIL

The AURON36 is designed to be the ultimate trail fork, with all the traction and support you need for climbing combined with all the control and playfulness for fun and efficiency on the decent. With stiff 36mm stanchions, an air EQ system and our all new RC+PCS Cartridge with semi open oil bath, you'll be ready for anything the trail can throw at you. Our RC+ cartridge has easy rebound and compression adjustability tuned to give excellent small bump performance and also to be highly efficient. With extra oil volume flow the RC+ PCS Cartridge has excellent small bump compliance along with being super stable. Combine the RC+ cartridge with a stiff chassis and QSP ports you can keep the AURON36 running smoother and longer. The RC+ Cartridge was developed by SR SUNTOUR engineers and top professional riders as part of our WERX program. It's the perfect weapon for trail and All Mountain bikes with 140-160mm of travel. The AURON36 is ready to tame any trail, are you?

29	140/150/160	220 MAX DISC	STANCHION: 36	E-BIKE READY	EQ.Mtr EQUALIZER	SOBA
27.5	140/150/160	220 MAX DISC	STANCHION: 36	E-BIKE READY	EQ.Mtr EQUALIZER	SOBA

<b>MODEL</b>	AURON36 EVO BOOST
<b>INTENDED USE</b>	ALLMOUNTAIN
<b>TRAVEL</b>	140, 150, 160 mm
<b>WHEEL SIZE</b>	27.5", 29"
<b>SPRING</b>	AIR EQ
<b>CARTRIDGE</b>	RC+
<b>BOTTOM CASE</b>	MAGNESIUM
<b>AXLE TYPE</b>	15AH2-110, OPTION 15LH-110
<b>FEATURES</b>	LONG FENDER MOUNT, DETACHABLE INTEGRATED SHORT FENDER

# TASTE OUR NEW SOBA SEMIOPEN OIL BATH



Extra juicy for the ultimate suspension experience. SOBA is based on high performance lubrication oil that works with our PCS dampers featured in RC+ versions of RUX, DUROLUX, AURON and starting with model year 2026 in AION series forks providing extra lubrication to keep your fork running smoothly, run after run. SOBA ensures that you'll get the right amount of oil to keep moistening the bushings and seals and can be easily refreshed with our lubrication bleed ports.



**SOBA**  
TECHNOLOGY



LEARN  
MORE!

# EQ EQUALIZER SYSTEM

FOR PRECISE & EFFORTLESS AIR SPRING TUNING



CLICK OR SCAN THE  
CODE TO WATCH THE  
DUROLUX EQ VIDEO

LEARN MORE AT [WWW.SRSUNTOUR.COM/EQ](http://WWW.SRSUNTOUR.COM/EQ)

# EQ EQUALIZER SYSTEM

FOR PRECISE & EFFORTLESS AIR SPRING TUNING

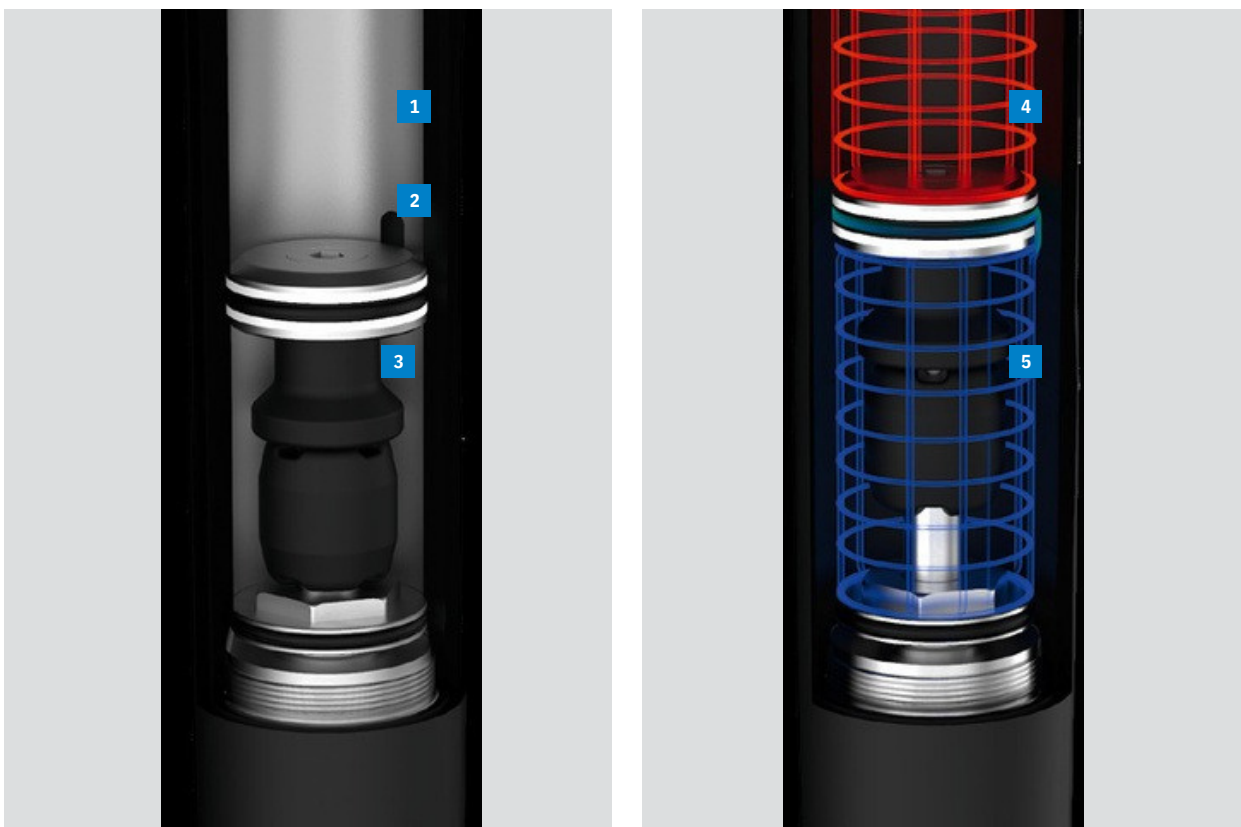

- 1 Positive air chamber
- 2 Transfer port
- 3 Negative air Chamber
- 4 Positive air pressure
- 5 Negative air pressure

## SET YOUR SAG AND THE EQUALIZER (EQ) AIR NEGATIVE SPRING SYSTEM WILL BALANCE IT FOR YOU.

Our tradition of product evolution brings our forks into a brand new era with our EQ air system. The EQ system perfectly balances positive and negative spring independent from rider weight, which results in amazing performance and precise support across the range. This customizes feel for each individual rider optimizing SAG and volume control. Pairing the EQ system with the external damping adjustments of our PCS cartridges promise a supple coil spring feel in a lightweight, progressive and easy to adjust air spring package. You can set your SAG according to your

intended riding style and the EQ system will balance it with the right amount of negative spring force helping you to create a precise and effortless tune. The EQ system will improve fork sensitivity of small repetitive bumps while providing plenty of mid-stroke support for those bigger hits resulting in enhanced comfort and performance when riding any kind of terrain.

### FUNCTIONAL FEATURES

- Greater, automatic spring adjustability based on the riding style and weight of the rider
- Improved fork sensitivity for those small but fast repetitive bumps
- Super consistent damping performance in tandem with the PCS system

## KEY SPECIFICATIONS



**SR SUNTOUR**  
**AURON36**

**SUGGESTED CATEGORY: ALL MOUNTAIN**

**TRAVEL: 140, 150 mm, 160 mm**

**STANCHION: Ø36MM, ALUMINUM ALLOY,  
HARD ANODIZED FINISH**

**SPRING: NEXT-LEVEL EQUALIZER® (EQ)  
AIR SPRING PERFORMANCE**



**COMPRESSION ADJUST: RC+**

**OFFSET: 44mm**

**BOTTOM CASE MATERIAL: MAGNESIUM**

**LUBRICATION PORT**

**CROWN/STEERER TUBE: C61 1.5" TAPER  
(OPTIONAL C74 1.8" TAPER) CTS (MY'26 C68 1.5"  
TAPER)**



**MAX BRAKE ROTOR: 220mm, 180mm DIRECT  
MOUNT**

**Ø15MM BOOST AXLE (TOOL TYPE)**

**TIRE SIZE & CLEARANCE: 29" X 2.6" MAX  
(67mm WIDTH, ETRTO 65-622), 27.5" X 2.6" MAX  
(67mm WIDTH, ETRTO 65-584)**

**FENDER MOUNT: SHORT & LONG MOUNTING  
POINTS**

## THRU AXLE INSTALLATION

### 15AH4 BOLTED THRU AXLE ASSEMBLY

**Note:** Before installation, make sure to check the o-ring is correctly seated at the thread part.

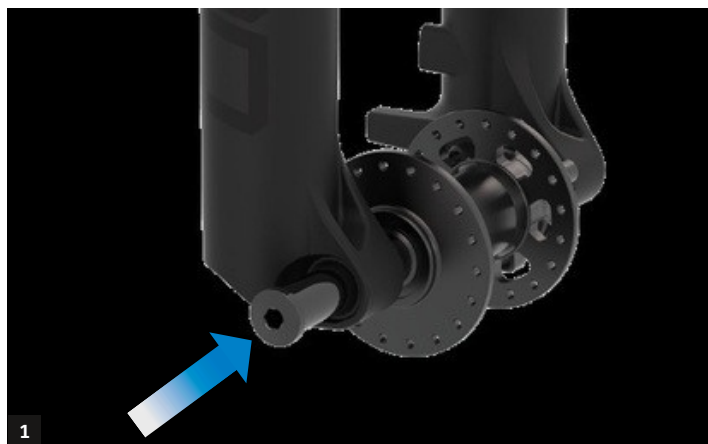

1 Fully insert the axle on the drive-side.



2 Tighten the axle with a 6mm Allen wrench by the suggested tightening torque of 8-10 Nm.



3 Check the axle's thread. It must be visible.

## THRU AXLE REMOVAL

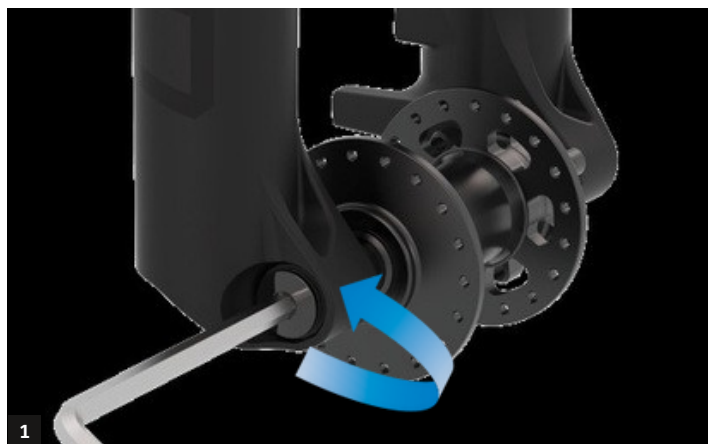

1 Loosen the axle on the drive side with a 6mm.



2 Pull out the axle.

## TERMS AND SETUP

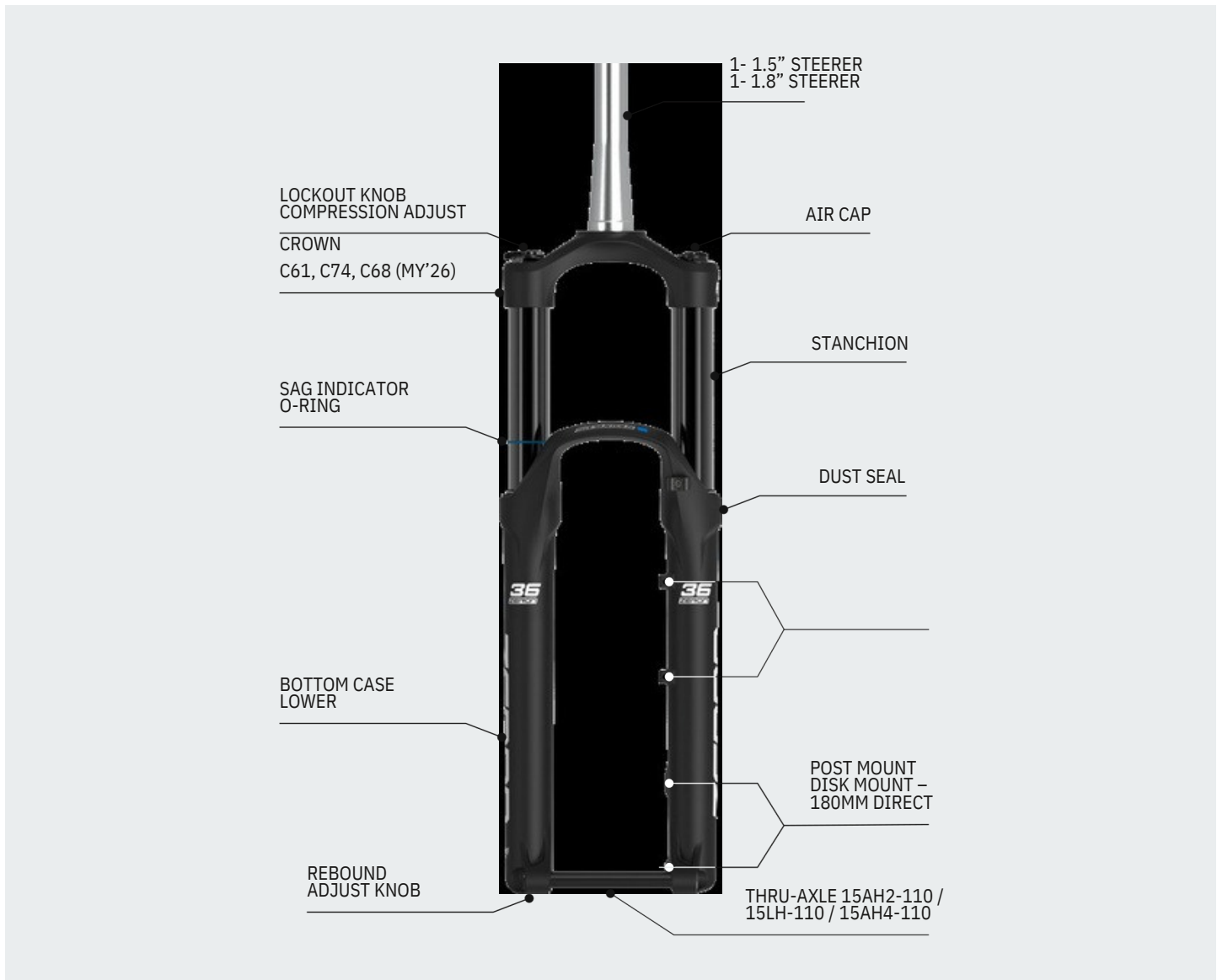

### TOOLS NEEDED FOR THE ADJUSTMENT SETUP

- High pressure shock pump (up to 300psi)
- 27mm socket (item code ZFC160-R)
- Tape measure or caliper (for setting the SAG)
- Protective gloves and eyewear

### BEFORE ADJUSTING YOUR FORK

The following setting recommendations have to be considered as starting points. After a few rides and once you get used to your fork, you might need to adjust it again so you feel even more comfortable and secure. Adjustments also depend on your riding style and the type of bike you use.

## SAG / AIR PRESSURE SETTING

SAG refers to how much the fork compresses under the rider's body weight while in a normal riding position with gear. It can be easily measured by checking the position of the blue SAG indicator O-ring on the fork stanchion. After setting the fork to the recommended air pressure based on the rider's weight (see chart below), the O-ring will indicate how much the fork has compressed by showing its position above the fork seal.

1. Turn the compression knob to put it in full open position.
2. Pump up to the suggested air pressure (refer to the chart below) and compress the fork at least 50% of full travel several times in order to equalize the air pressure between the positive and negative air chamber.
3. Sit on the bike with equipment (such as backpack) and ask somebody to hold the bike, stand on the pedals, and compress the fork several times. Then sit on your bike in your normal riding position.
4. Slide the SAG indicator O-ring down to the top of the dust seal.
5. Gently step off the bike without compressing the fork furthermore.
6. Check the O-ring position to see if the SAG setting is properly done.
7. In case if the SAG setting is not properly done, air pressure must be adjusted.
  - In order to increase the SAG, decrease the air pressure.
  - In order to decrease the SAG, increase the air pressure.

Repeat the above procedure until you can find the correct SAG setting.



## SAG / AIR PRESSURE SETTING

PER FORK STOCK TRAVEL	SAG MIN.-MAX. (mm)
140mm	21-42mm(15-30%)
150mm	22-45mm(15-30%)
160 mm	24-48mm(15-30%)

RIDER WEIGHT (KG)	(lbs)	RECOMMENDED AIR PRESSURE
< 55 kg	< 121 lbs	50 - 70 psi
55 - 65 kg	121 - 143 lbs	70 - 80 psi
65 - 75 kg	143 - 165 lbs	80 - 90 psi
75 - 85 kg	165 - 187 lbs	90 - 100 psi
85 - 95 kg	187 - 209 lbs	100 - 125 psi
95 < kg	209 < lbs	125+ psi
PRESSURE (FACTORY SETTING)		125 psi
MAX. PRESSURE		145 psi

### WARNING

Do **not exceed** max air pressure of 145Psi. Failure to comply with these instructions may cause serious damage to your product, injury or even death.

## REBOUND SETTING



Rebound controls the speed of the fork extension after compression. Always start the rebound setting process with the rebound knob (located bottom of the drive-side of the fork) in closed position by turning the adjuster knob all the way to the end of the clock-wise position (+).

### TO OPEN THE LOW-SPEED REBOUND

Turn the knob counter-clockwise toward the (-) to open the low-speed rebound. Each click allows the fork rebound faster per progression.

**Note:** Rebound tuning is relative to air pressure setting. Higher pressure should tune toward closed(+) setting. Lower pressure, in contrast, should set toward faster open setting (-).

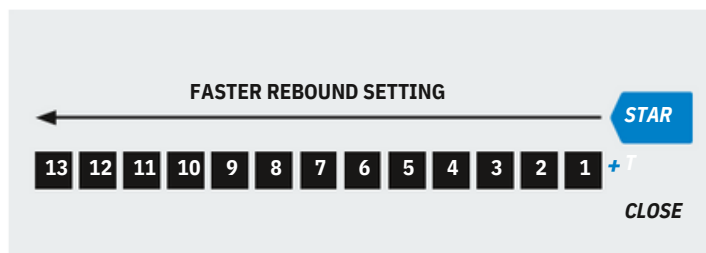

For faster rebound, the counter clock-wise tuning should allow rider to stay leveled through fast and continuous bumps, causing compression to sink from mid to end of the stroke, thus increase chances of bottoming out and harsh impact and lost of traction.

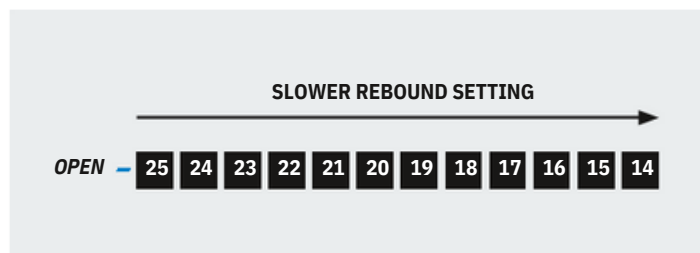

For slower rebound, the clock-wise tuning should allow rider to skip over rougher terrain at slower speeds. Eliminating sharper feedback and gaining control in technical routes and jumps.

## AIR VOLUME SETTING

### VOLUME SPACERS

are available to further tune the air pressure setting by condensing the available air in piston chambers. Therefore, Making the fork compression more progressive and bottom-out resistant.

1. Make sure your fork is clean and free of any dirt, grease, moisture.
2. Unscrew and remove the Air cap (1).
3. Release ALL air pressure from the fork.
4. Use a 27mm socket tool (item code ZFC160-R) to loosen the Air cap assembly (2).
5. Pull out the Air cap assembly and add or remove the desired quantity of spacers to use in your fork (please refer to the next page).
6. Be sure to apply grease onto the O-ring seal (3) to ensure a good sealing.
7. Re-insert the Air cap assembly (2) back into the stanchion and tighten the unit to appropriate torque (20Nm) per user manual.
8. Inflate the fork to the appropriate setting of choice with a shock pump.

### ⚠ WARNING

Improper installation of the volume spacers from above instruction may result in severe injury or death.



# AIR VOLUME SETTING

## VOLUME SPACERS

Adjust your spring curve by using different amount of rubber volume spacers (FEG270-30). More spacers for more progression from mid-stroke to end of travel stroke. Less spacer for more comfort.

AURON36 EVO		
FEG270-30 volume spacers	Factory setting	Max. possible spacers
Travel 160	3	4
Travel 150	4	5
Travel 140	5	5

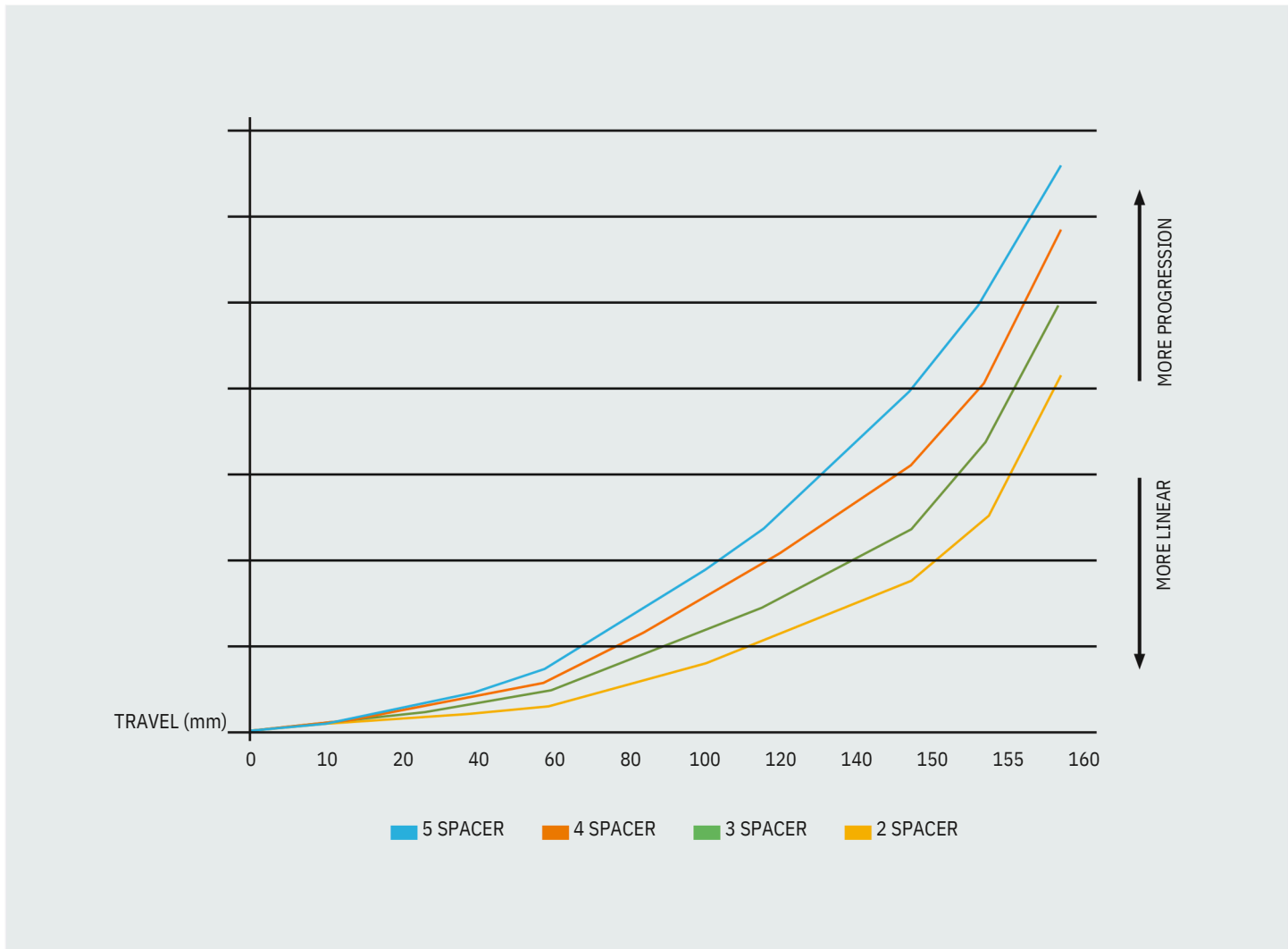

## COMPRESSION ADJUSTMENT

### RC+

**To open the low-speed compression:** Turn the right-side adjuster knob counter-clockwise towards the (-) direction.

**Result:** Compression is tuned to provide a supple feel with sensitivity on small bumps.

**To close the low-speed compression:** turn the right-side adjuster knob clockwise toward the (+) direction.

**Result:** By closing the compression, the compression will feel firmer for more predictable and supported ride.



### RC+

#### RIDE BOLD

Extra oil flow for high speeds and hard impacts

Our new RC+ cartridge has extra oil flow for high speeds and hard impacts while still offering excellent performance for both small bumps and trail chatter. With a new semiopen oil bath & easy adjustment it means the best stability and suspension for you on the trail. RC+ is developed by our SR Suntour engineers and top professional riders as part of our WERX program.

#### RC+ PCS Cartridge Features

- Extra oil flow for high speeds and hard impacts while still offering excellent performance for both small bumps and trail chatter
- Internal shim based high speed compression and rebound management
- External low speed compression & rebound adjust
- High and low speed circuit work independent but transition seamlessly into each other
- Race proven WERX cartridge with PCS (Piston Compensator System) floating piston provides consistent damping in all conditions, eliminating cavitation
- Updated internal seals greatly improve durability for Trail/AM and Enduro usage
- Forged alloy adjust knobs with integrated design and light „Click“ index feeling for easy and sure operation

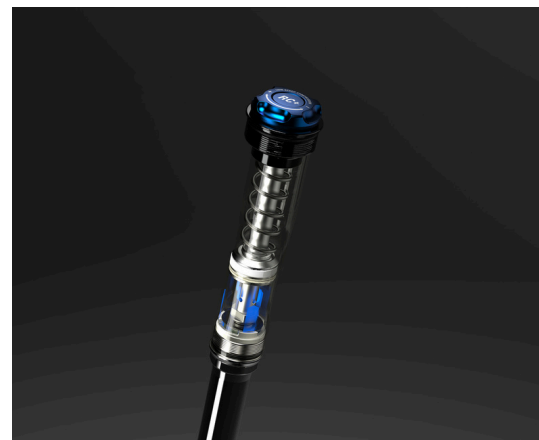

## QUICK SERVICE PORTS (QSP)

Quick service ports are provided for easy relubrication and air release. While the QSP doesn't replace regular service intervals as recommended in our manual they're useful for releasing trapped air pressure from the lower legs and for quickly lubricating the foam wipers between services.

### RELEASE OF PRESSURE

Long and hard rides can sometimes cause air pressure to build up in the fork legs. Open the QSP port screws by using a 2.5mm allen key to release any possible built-up pressure. Retighten.

### LUBRICATION

Using a 2.5mm allen key, remove the screws and o-rings from the QSP ports. Fill a M6 threaded syringe with 15wt oil (air side)/5wt oil (cartridge side) and plug into the QSP port. Gently compress the syringe until you feel a bit of resistance. Compress and release the fork a few times and then disconnect the syringe (some oil can come out at this stage; this is normal). Replace the screw and o-ring. Repeat the process on the other side.

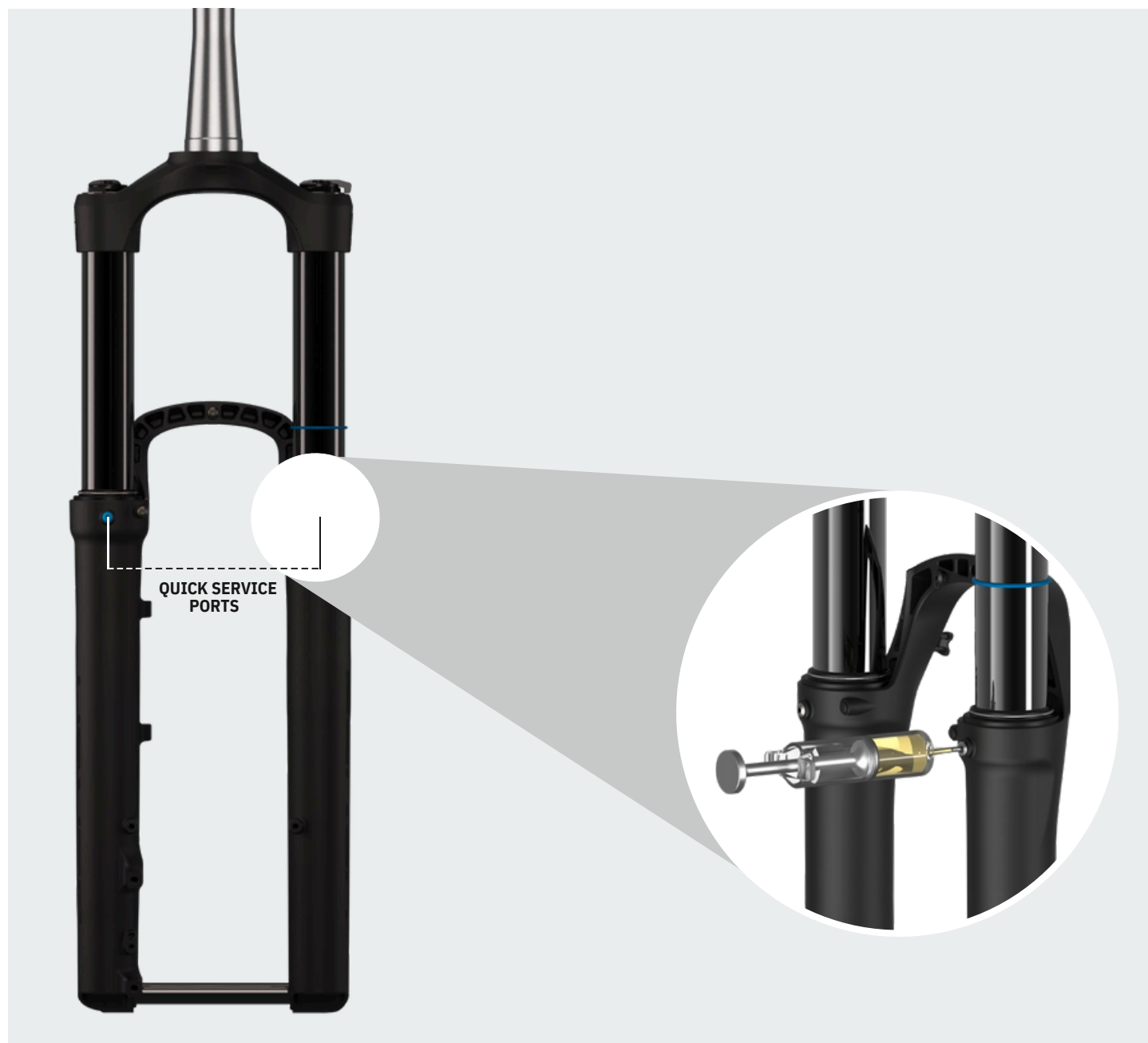

## SERVICE INTERVALS GUIDE

Service intervals guide are provided to allow our customer to keep his product running in the best way possible. Following this protocol assure customer to keep SR SUNTOUR product as good as new.

**After every ride:** Clean stanchions and dust wipers with light soapy water and wipe dry. Check the stanchion tubes for dents, scratches or other discoloration.

**Before each ride:** Check your SAG and adjust the pressure if necessary. Check the damper adjustments (compression/lockout and/or rebound)

**Every 50 hours:** Maintenance 1 (at the dealer)

**Every 100 hours or once a year:** Maintenance 2 (at the dealer, ideally before winter time in order to protect all parts from the effects of weather by proper greasing).

RECOMMENDED SERVICE ITEMS	AFTER EACH RIDE	AFTER 25 HOURS	AFTER 50 HOURS OR 6 MONTHS	AFTER 100 HOURS OR 12 MONTHS
Clean stanchion tubes and dust seals with soapy water and rinse with clear water	•			
Inspect stanchion tubes for wear	•			
Check fixing bolts and quick release for proper torque	•			
Clean fork with light soapy water and wipe dry	•			
Check air pressure and SAG		•		
Remove the quick release, check for deep marks in the fork dropouts		•		
Lower legs service			•	•
Air chamber service				•
Cartridge service				•

## SERVICE GUIDES

All the information you need to keep your Sr Suntour product working perfectly.

### WARNING

Carefully read, understand and follow the instructions provided in this manual, and keep it in a safe place for future reference. If you have any doubt whatsoever regarding the use or maintenance of any SR SUNTOUR product, please contact SR SUNTOUR. Failure to follow these warnings and instructions can result in product malfunction, causing an accident, severe injury or death.

## IMPORTANT SAFETY INFORMATION

- Read this manual thoroughly before using your suspension system.
- These instructions contain important information about the correct installation, service and maintenance of your suspension fork. Common mechanical knowledge may not be sufficient. Your suspension fork should only be installed, serviced and/or maintained by a trained and qualified bicycle mechanic with specialized tools.
- Our suspension systems contain fluids and gases under extreme pressure. Never try to open any SR SUNTOUR suspension system! Pieces can be violently ejected.
- SR SUNTOUR suspension forks are designed as a single integrated system. To avoid product malfunction and an accident, use only genuine SR SUNTOUR spare parts. The use of third-party supplier spare parts also voids the warranty of your suspension system.
- Your suspension fork is not intended for jumps, aggressive downhill rides, freeride or dirt jumping if the warning sticker on your suspension system prohibits these activities. Disregarding these instructions may cause your suspension fork to fail, resulting in an accident, personal injury or death, and will void the warranty.

### WARNING

- SR SUNTOUR suspension fork is designed for use by a single rider.
- Select the correct suspension fork according to your frame's dimensions and your personal riding style. Installing a suspension fork which does not match the geometry of your frame could result into a failure of the suspension fork or frame could result into a failure of the suspension fork or frame itself and will void the shocks warranty. Failure of the suspension fork or frame itself and will void the shocks warranty.
- Know the limits of your skill and experience, and never ride beyond them.
  - Read, understand and follow all owner's manuals provided with your bike and all of its components.
- Always be equipped with proper safety gear. This includes a properly fitted and fastened helmet.

## BEFORE EVERY RIDE

- Inspect your bicycle and suspension system including the handlebars, pedals, crank arms, seat post, saddle, etc. For any cracks, dents, bent or tarnished parts, Also search for any oil leaking out of your shocks. Be sure to check hidden areas on the underside of your bike. If any condition exists, consult a trained and qualified bicycle mechanic to determine the cause and make any necessary correction.
- Compress your suspension system with your body weight. If it feels too soft, make the necessary adjustments until you have reached the correct SAG value. Please also see the instruction in this manual regarding SAG.
- Make sure your brakes are properly installed/adjusted and work correctly.
- Spin the wheels. Make sure that wheels are perfectly centered and do not contact the suspension fork or brakes.
- If you are using a quick release system to fasten your wheel set, make sure that all levers and nuts are properly tightened. In case you are using a through axle system, make sure that all fixing bolts are tightened with the appropriate torque values. Strictly follow the instructions provided by the manufacturer of the quick release or through axle system.

## LOWER LEGS SERVICE

---

### REQUIRED TOOLS & SUPPLIES:

- Ratchet wrench
- 10mm socket
- 12mm socket
- Torque wrench (8-12N.m)
- Plastic mallet
- Rag or workshop towel
- Bucket to collect oil
- Downhill tyre removal tool
- 36mm Dust seal installer (Sr Suntour fork Toolbox)
- SR SUNTOUR “Low friction” grease or suspension grease without lithium
- SR SUNTOUR suspension oil (5WT and 15WT Suspension oil).
- Brush
- Lower legs service kit : FKA122-04

### WARNING

Do not attempt this intervention without the proper tool, you may damage your Sr Suntour product

### WARNING

Always wear safety glasses and protective gloves during the maintenance of SR SUNTOUR products.

## LOWER LEGS SERVICE

---

### STEP 1

---

On the damper side, pull off the rebound adjuster knob to remove it, then set it aside.



### STEP 2

---

Using an 12mm socket, turn the exposed bolt counterclockwise 2 turns to loosen it.



Put a socket on the bolt, use a mallet to strike the socket 2-3 times. Check to ensure the bolt is in contact with the leg. Remove the bolt and set it aside.



## LOWER LEGS SERVICE

### STEP 3

On the air/spring side, use a 10mm socket, turning it counterclockwise 3-4 turns to loosen the bolt. Keep the socket on the bolt, use a mallet to strike the bolt 2-3 times. Check to ensure the nut is in contact with the leg.



Remove the nut and set it aside. Pull on the lower legs to remove them, and set them aside.



#### **⚠ WARNING**

This product have lubrication oil in the lower legs

#### **⚠ WARNING**

Before removing lower legs, prepare a bucket to receive oil lubrication.

### STEP 4

#### A)FOAM RING and LOWER LEGS maintenance

Carefully remove the foam rings with a pick and rinse with degreaser. Remove the degreaser by pressing them using a clean rag. Repeat the process if necessary.



Remove the degreaser by pressing them using a clean rag. Repeat the process if necessary.



## LOWER LEGS SERVICE

Use a workshop towel to clean the inner walls of the lower legs.



Soak the foam rings into 15WT 100% synthetic suspension oil for 5-10 minutes and reinstall them.



### STEP 4

#### B) DUST SEAL AND BUSHING LUBRICATION

If the dust seals are in good condition, simply clean and degrease them using a clean workshop rag or towel. Clean and grease the bushings as well as the dust seals using the dedicated SR SUNTOUR “Low-Friction” grease.



## LOWER LEGS SERVICE

### STEP 5 – NEW DUST SEAL / FOAM RINGS

Hold the lower legs and remove the dust seals using a DH tire removal tool. If using a wrench, use caution not to damage the inside of the lowers.



Remove the foam rings from both sides and discard them.



Use a workshop towel to clean the inner walls of the lower legs.



Take the new foam rings and soak them in 15wt oil for 5-10 minutes.

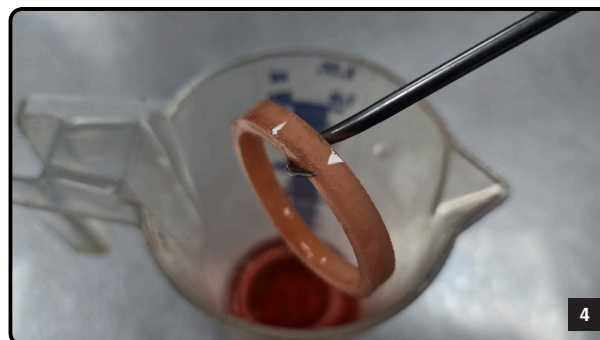

Place the new dust seal onto the dedicated installation tool and press the seal by hand into the fork lowers.



## LOWER LEGS SERVICE

Hold the lower legs with one hand and finish the installation by tapping the installation tool with a plastic mallet. Once you hear a change in the tapping sound, remove the tool and check that the seal edge is flush with the lower leg. If necessary, repeat the process until the seal is flush with the lower leg.



Install the new foam rings.



Grease the bushings and dust seals using the dedicated SR SUNTOUR “Low-Friction” grease.



## STEP 6

Clean the stanchions. Fully extend the damper cartridge and install the lower legs.

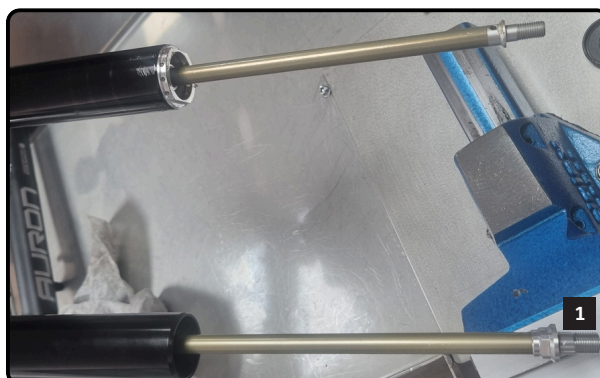

## LOWER LEGS SERVICE

### STEP 7

Place the lower legs with the cartridge and air side 5mm inside the legs.



Use a serynge to add 10CC of 15WT(air side) and 15CC of 5WT (cartridge side) of suspension oil.



Push the lower so the cartridge and air shaft will get out of the lower legs.



## DAMPER SIDE

First install both washer and nut by hand.



Use a 12mm socket to tighten the bolt to 8Nm.



## LOWER LEGS SERVICE

### AIR SIDE

Install both the washer and nut.



Use a torque wrench with 10mm socket and tighten to 8Nm.



## AIR CHAMBER SERVICE

---

### REQUIRED TOOLS & SUPPLIES:

- Ratchet wrench
- 27mm socket (ZFC160-R)
- 12mm socket
- 10mm socket
- 5mm allen key
- 2.5mm allen key
- Torque wrench (8-20N.m) with 28mm crowfoot wrench
- 10mm shaft clamp
- Loctite 542 or equivalent
- Pliers (smooth jaw, flat surface) or 28mm wrench
- Plastic mallet
- 3mm Pin Punch
- O-ring removal tool
- Air chamber oil (15W50 synthetic oil)
- Rag or workshop towel
- SR SUNTOUR “Low friction” grease or suspension grease without lithium
- Brush
- High pressure pump (Shock pump)
- Air chamber seal kit : FKA121-24

### ⚠ WARNING

Always wear safety glasses and protective gloves during the maintenance of SR SUNTOUR products.

### ⚠ WARNING

Do not attempt this intervention without the proper tool, you may damage your Sr Suntour product

### GENERAL INFORMATION

All EQ forks can be identified by the EQ sticker on the crown of the fork.



## AIR CHAMBER SERVICE STEP 1

---

Remove the lower legs. Refer to the procedure “LOWER LEGS SERVICE...” specific to your fork.

---

## STEP 2

Remove the air cap and depressurize the air chamber.



## STEP 3

Use the dedicated 27mm socket and a ratchet to unscrew the air cap assembly (picture 1). Carefully remove the air cap assembly from the stanchion and set it aside (picture 2).



## AIR CHAMBER SERVICE

---

### STEP 4

---

Use a 28mm wrench or a Knipex smooth-jaw pliers to unscrew the nose piece by turning it counterclockwise

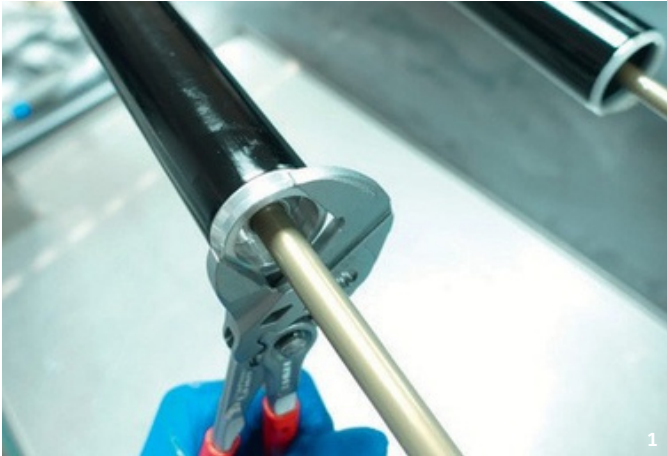

### STEP 5

---

Move the nose piece partway down the shaft (picture 1). Pull the shaft and remove the air shaft assembly. Set it aside (picture 2). If air shaft is inside the leg after removal of air pressure, this is normal, just pull harder on the shaft and it will go out.



### STEP 6

---

Spray isopropyl alcohol on a workshop towel. Use a shaft to push the towel through the stanchion. Inspect the inner surface of the stanchion and check for potential scratches.

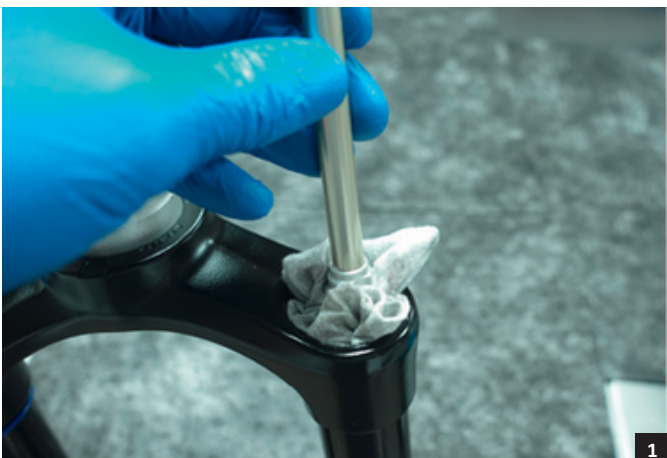

## AIR CHAMBER SERVICE

### STEP 7

Slide the spacer, bumper, and nose piece down to expose the shaft. Clean the shaft with brake cleaner and a workshop towel. Use 10 mm clamps to hold the shaft in a vise.

**Note:** Leave a 20 mm gap between the piston and the clamps so that the shaft is not put under stress.

Hold the shaft horizontally in a vise. Note the position of the pin in the piston head. Use a 3mm pin punch with a mallet to free the piston from the shaft head. Use a 5mm allen key to untighten (counterclock) the head of the shaft.

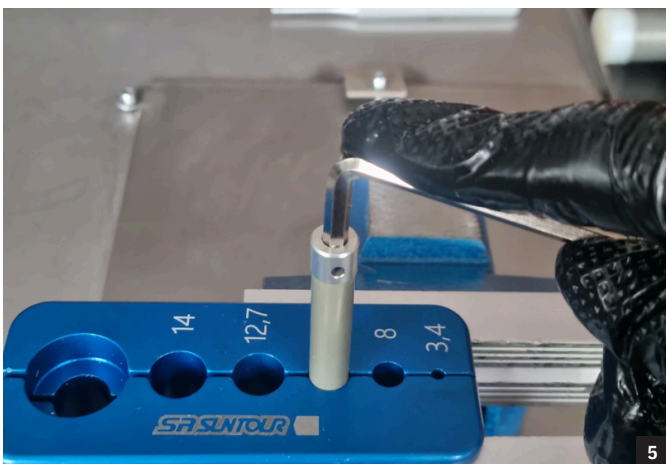

## AIR CHAMBER SERVICE

---

### STEP 8

---

Remove the shaft from the vise. Remove the plastic spacer, bumper and nose piece from the shaft and set them aside.



## AIR CHAMBER SERVICE

### STEP 9

Use a pick to remove the x-ring.



Clean the seal seat with a rag. Grease and install the new x-ring.



Make sure the seal is seated correctly without any twists.



## AIR CHAMBER SERVICE

Remove the O-ring and set it aside. Clean the seal seat, apply grease to the new O-ring, then install it.



## AIR CHAMBER SERVICE

### STEP 10

Hold the piston and remove the two backup rings and the x-ring seal. Clean the piston.

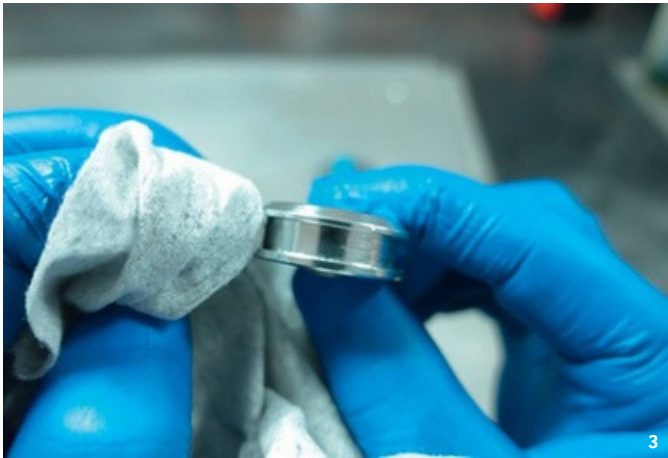
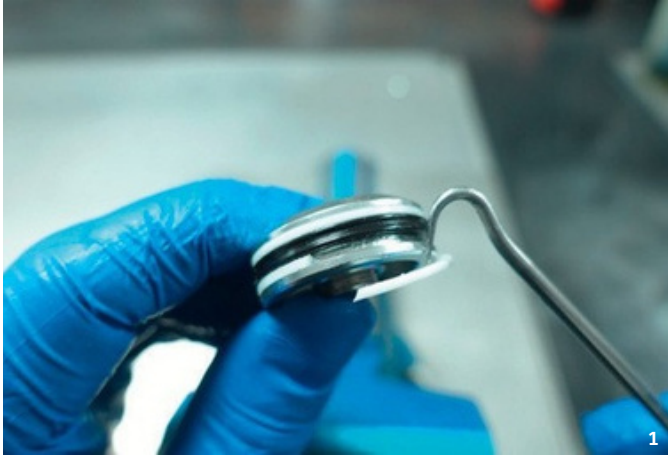

### STEP 11

Install the first backup ring, making sure it is properly seated. Apply SR SUNTOUR “Low-Friction” grease on the new x-ring and install it. Install the second backup ring.

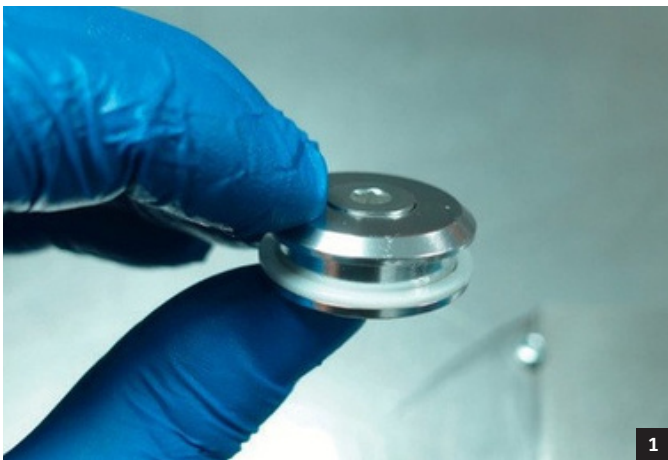

## AIR CHAMBER SERVICE

---

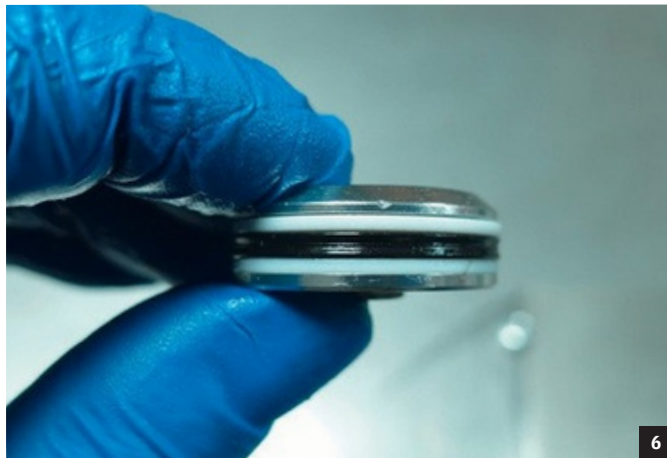

### STEP 12

Apply SR SUNTOUR “Low Friction” grease on the inside of the rubber bumper, plastic spacer and nose piece. Use a bullet tool to install them on the shaft in the correct order (refer to picture 5).



## AIR CHAMBER SERVICE



### STEP 13

Use 10mm clamps to secure the shaft in the vise.

**Note:** Leave a 20mm gap between the piston and the clamps so that the shaft is not put under stress.

Apply Loctite 262 or equivalent to the shaft head threads. Use a torque wrench with a 5mm Allen bit and tighten the shaft head to **6Nm**. Put the shaft in horizontal position, put the pin in the noted position, use 3mm pin punch to put it back in position.

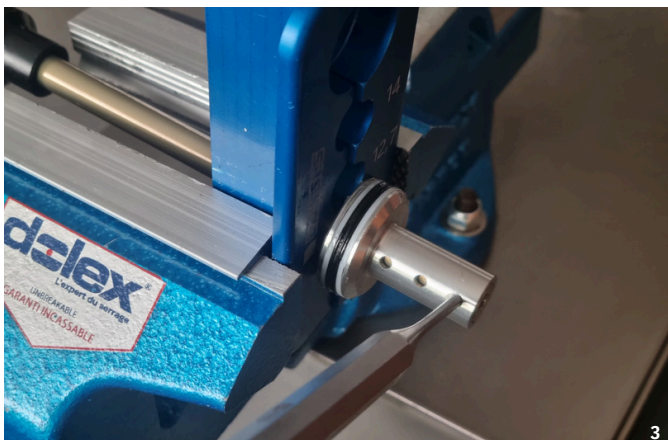
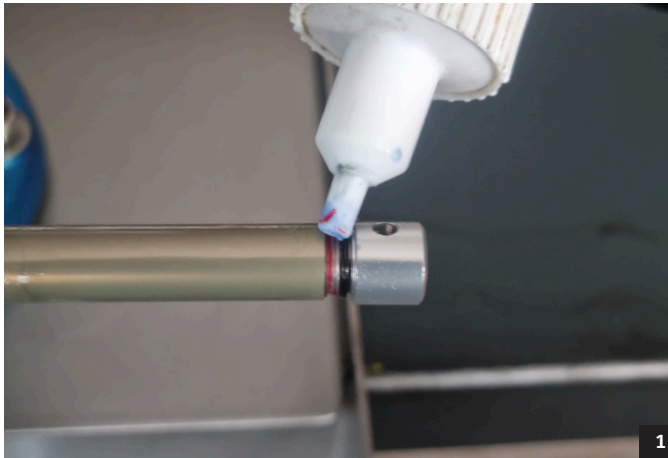

## AIR CHAMBER SERVICE

### STEP 14

Apply SR SUNTOUR “Low-Friction” grease to the piston x-ring seal, the nose piece O-ring, and the inside of the stanchion.

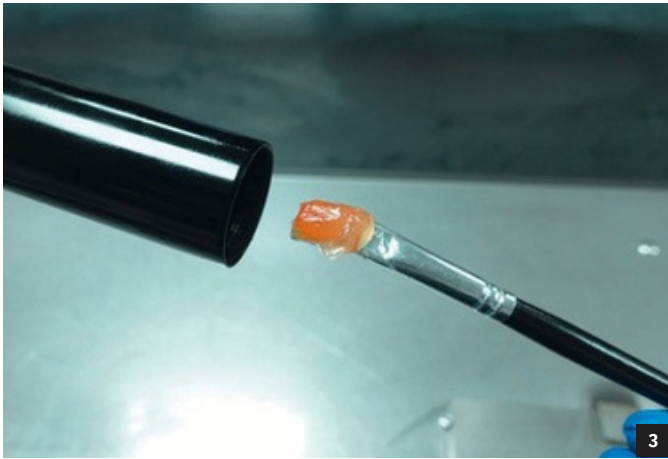

### STEP 15

Insert the air shaft assembly into the stanchion. Begin threading it by hand and finish with a torque wrench set to **2.7 Nm**.

**Note:** Do not exceed 2.7Nm of torque, as this could damage the stanchion.

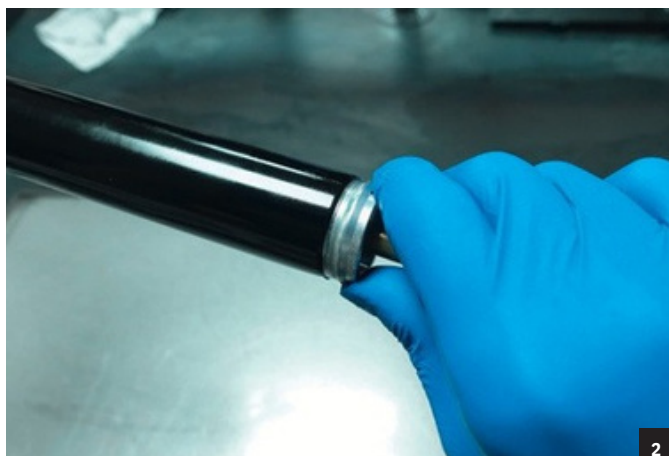

## AIR CHAMBER SERVICE

---



### STEP 16

---

Inject 1-2cc of air chamber oil (15w50 synthetic oil) directly in the stanchion.

**Note:** Do not exceed 2cc of oil, as too much could block the air transfer between the positive and negative air chambers.



Apply grease to the air cap assembly o-ring.



## AIR CHAMBER SERVICE

---

### STEP 17

---

Install the air cap assembly in the left stanchion using the dedicated 27 mm socket and ratchet, and tighten to **15Nm**.



### STEP 18

---

Clean the stanchions.



Prepare the lower leg assembly. For more details, please refer to the “LOWER LEG SERVICE...” guide specific to your fork for detailed instructions.

In summary, start by cleaning the lower legs bushings. Clean or replace the dust seals and foam rings.

Grease the inner surface of both dust seals and bushings with SR SUNTOUR “Low friction” grease. Soak the foam rings with 15wt oil, then reinstall.

## AIR CHAMBER SERVICE

---

### STEP 19

---

Pressurize the air spring to 70 psi and equalize the positive and negative chambers by compressing the fork a few times within the sag portion of the fork travel.



## TRAVEL CONVERSION

---

### REQUIRED TOOLS & SUPPLIES:

- 27mm socket (ZFC160-R)
- Ratchet wrench
- 12mm socket
- 10mm socket
- Torque wrench with 28mm crowfoot wrench
- 10mm alloy shaft clamps
- 3mm Pin Punch
- Plier wrench (flat surface) or 28mm wrench
- Plastic mallet
  
- Air chamber oil or 15W50 synthetic oil
- SR SUNTOUR “Low-Friction” grease or suspension grease without lithium
- Brush
- Rag or workshop towel

### **⚠ WARNING**

Always wear safety glasses and protective gloves during the maintenance of SR SUNTOUR products.

### **⚠ WARNING**

Do not attempt this intervention without the proper tool, you may damage your Sr Suntour product

### GENERAL INFORMATION

All EQ forks can be identified by the EQ sticker on the crown of the fork.



## TRAVEL CONVERSION

---

### STEP 1

---

Remove the lower legs. Refer to the procedure “LOWER LEGS SERVICE...” specific to your fork.

### STEP 2

---

Remove the air cap and depressurize the air chamber.



### STEP 3

---

Use the dedicated 27mm socket and a ratchet to unscrew the air cap assembly (picture 1). Carefully remove the air cap assembly from the stanchion and set it aside (picture 2).



### STEP 4

---

Use a 28mm wrench or a smooth-jaw pliers to unscrew the nose piece by turning it counterclockwise.



## TRAVEL CONVERSION

---

### STEP 5

---

Move the nose piece partway down the shaft (picture 1). Pull the shaft and remove the air shaft assembly. Set it aside (picture 2). If the shaft go inside after air removal, it's normal, just pull it harder to get it off.



### STEP 6

---

Spray isopropyl alcohol on a workshop towel. Use a shaft to push the towel through the stanchion. Inspect the inner surface of the stanchion and check for scratches.

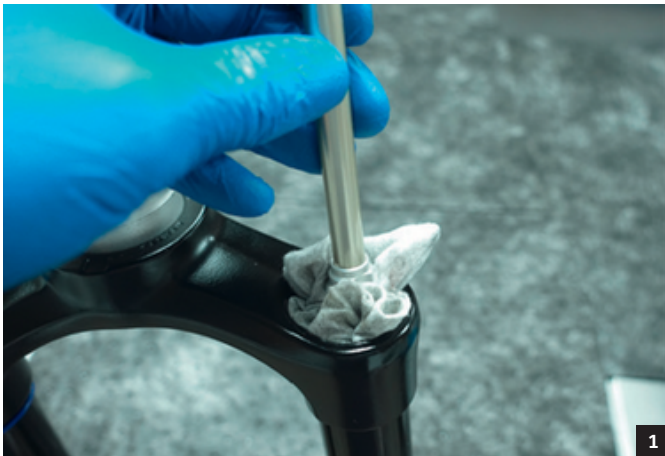

## TRAVEL CONVERSION

---

### STEP 7

---

Slide the spacer, bumper, and nose piece down to expose the shaft. Clean the shaft with brake cleaner and a workshop towel. Use 10mm clamps to hold the shaft in a vice.

**Note:** Leave a 20mm gap between the piston and the clamps so that the shaft is not put under stress.

Put the shaft horizontally in the vice. Use a 3mm pin punch with a mallet to remove pin from piston head.



### STEP 8

---

Without the pin, piston head is free to move, you can change travel by moving it up or down. There is a difference of 10mm of travel between each slot.



## TRAVEL CONVERSION

---

### STEP 9

---

Put the shaft horizontally in the shaft. With the 3mm pin punch and the mallet, put back the pin in place at the travel slot of your choice.

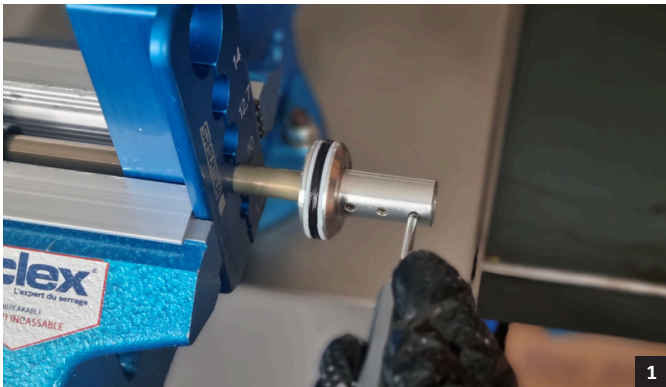

### STEP 10

---

Apply SR SUNTOUR “Low-Friction” grease to the piston x-ring seal, the nose piece O-ring, and the inside of the stanchion.



## TRAVEL CONVERSION

### STEP 11

Insert the air shaft assembly into the stanchion. Begin threading it by hand and finish with a torque wrench with 28mm crowfoot set to **2.7 Nm**. **Note: Do not exceed 2.7Nm of torque, as this could damage the stanchion.**



### STEP 12

Inject 1-2cc of air chamber oil (15W50 synthetic oil) directly in the stanchion (picture 1). Apply grease to the air cap assembly o-ring (picture 2).



### STEP 13

Install the air cap assembly in the left stanchion using the dedicated 27mm socket and ratchet, and tighten to **15Nm** (picture 1). Pressurize the air chamber to 80 psi (picture 2).



## TRAVEL CONVERSION

---

### STEP 14

Clean the stanchions.



Prepare the lower leg assembly. For more details, please refer to the “LOWER LEG SERVICE...” guide specific to your fork for detailed instructions.

In summary, start by cleaning the lower legs bushings. Clean or replace the dust seals and foam rings.

Grease the inner surface of both dust seals and bushings with SR SUNTOUR “Low friction” grease. Soak the foam rings with 20wt oil, then reinstall.

## TRAVEL CONVERSION

---

### STEP 16

---

Pressurize the air spring to 70 psi and equalize the positive and negative chambers by compressing the fork a few times within the sag portion of the fork travel.



# CARTRIDGE REPLACEMENT AND BLEEDING

## REQUIRED TOOLS & SUPPLIES:

- 27mm socket (ZFC160-R)
- Ratchet wrench
- 12mm socket ( RC+ cartridges forks)
- 2mm allen key and one 14G spoke
- Torque wrench (8-20N.m)
- Plastic mallet
- Rag or workshop towel
- Plastic tyre lever
- SR SUNTOUR suspension oil or 5WT suspensionoil
- SR SUNTOUR 27.7mm cartridge clamp

### ⚠ WARNING

Do not attempt this intervention without the proper tool, you may damage your Sr Suntour product

### ⚠ WARNING

Always wear safety glasses and protective gloves during the maintenance of SR SUNTOUR products.

## STEP 1

Fully open rebound and compression settings. Remove the rebound lever



## STEP 2

Using an 12mm socket, turn the exposed bolt counterclockwise 2 turns to loosen it. Put a socket on the bolt, use a mallet to strike the socket 2-3 times. Check to ensure the bolt is in contact with the leg. Remove the bolt and set it aside.



## CARTRIDGE REPLACEMENT AND BLEEDING

---

### STEP 3

---

Remove rebound nut and push rebound shaft



**⚠ WARNING**

This product have lubrication oil in the lower legs

**⚠ WARNING**

Before removing cartridge, prepare a bucket to receive oil lubrication.

### STEP 4

---

Use a plastic tyre lever to pull out compression knob



### STEP 5

---

Use the wrench with 27 socket to untighten top end of the cartridge.



## CARTRIDGE REPLACEMENT AND BLEEDING

---

### STEP 6

---

Pull out the cartridge of the fork



### STEP 7

---

Put the cartridge in full extension by pulling the rebound shaft. Position the Sr Suntour clamp on the cartridge, right over the connection between the black parts and the grey parts.

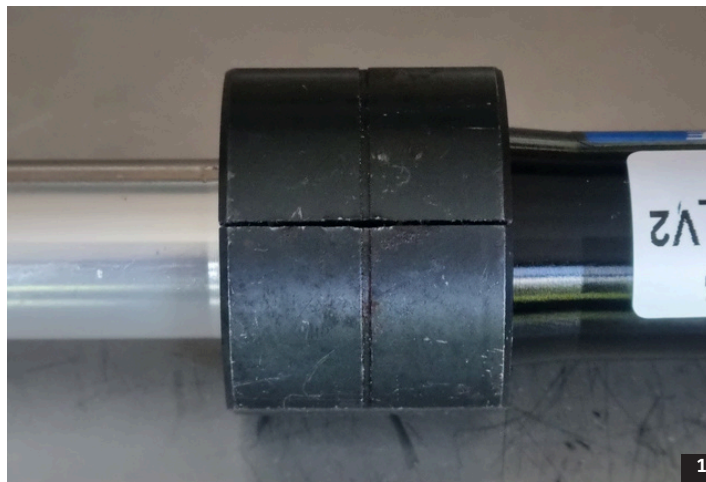

## CARTRIDGE REPLACEMENT AND BLEEDING

### STEP 8

Localize the bleed hole on the black parts of the cartridge and seal it with a vinyl tape.

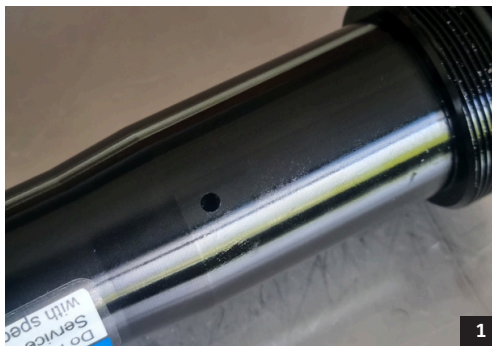

### STEP 9

Install the cartridge in the vise in vertical position. Use the 27mm socket to untighten the top cap (counterclockwise) of the cartridge. Remove the spring.



### STEP 10

Slowly push the rebound shaft completely in. Floating piston will come up.



## CARTRIDGE REPLACEMENT AND BLEEDING

---

### STEP 11

With a 2mm allen key, remove bleed screw off the floating piston. With a spoke, screw it in the bleed port, pull out floating piston off the cartridge.



### STEP 12

Remove the cartridge from the vice, put the cartridge upside down to remove the oil by gravity, move the rebound shaft to remove the remaining oil.



### STEP 13

Put the cartridge back in the vice, pour SR SUNTOUR suspension oil or 5WT suspension in the cartridge.

Slowly move the rebound shaft up and down, no more bubbles should appear during this movement.

When rebound shaft is fully in, oil level need to be at 35mm from top. Move shaft until no bubble visible. Add oil until level is good.



## CARTRIDGE REPLACEMENT AND BLEEDING

---

### STEP 14

Place the pcs piston back in the cartridge, push it to reach 35mm depth, be sure that oil is going over the piston. Then, put back the 2mm bleed screw. Tighten it at 3N.m.



### STEP 15

In the same time, pull the rebound shaft down and push the floating piston down with an allen key. When cartridge fully extended, put back spring over the floating piston and close the top cap with the 27mm socket. Tighten it at 10N.m. Remove the vinyl tape that cover the hole.



### STEP 16

Put back the cartridge in the fork, tighten upper parts at 20N.m



## CARTRIDGE REPLACEMENT AND BLEEDING

---

### STEP 12

Put 15cc of SR SUNTOUR suspension oil or 5WT suspension oil in the lower, put back the cartridge nuts, tighten at 8N.m and put the rebound knob.



EVO Boost EQ  
RC4-PCS 29"



MODEL NAME	MAIN SPECIFICATIONS									CROWN		STANCHION		STEERER TUBE		AXLE		BOTTOM CASE / BRAKE	
	E-Brake ready	Weight (g) w/o axle	Wheel / Max. suggested tire size	Max allowed Tire Width	Max allowed Tire O.D.	Travel (mm)	Damper	Spring	Offset (mm)	Mat.	DIA (mm)	Mat.	Finish	Size Material	O.L.D.	Axle	Mat.	Max rotor DIA	Brake mount
SF25-AURON36-Boost EQ RC4-PCS DS 15AH4-110 29"	no	-	29"x2.6"	67mm	756mm	140/150/160	RC4-PCS	AIR (EQ)	44	Hollow Alloy	36	Al	HARD ANODIZED BLACK	1.5"to1-1/8" tapered (CTS) Alloy STEERER	ø15-110	15AH4-110	Mg	220mm	Post 180 Direct
SF25-AURON36-Boost EQ RC4-PCS DS 15AH4-110 27.5"	no	-	27.5"x2.6"	67mm	723mm	140/150/160	RC4-PCS	AIR (EQ)	44	Hollow Alloy	36	Al	HARD ANODIZED BLACK	1.5"to1-1/8" tapered (CTS) Alloy STEERER	ø15-110	15AH4-110	Mg	220mm	Post 180 Direct

## REFINED SIMPLICITY

---

SR SUNTOUR is a Japanese owned bicycle component, suspension and drivetrain product manufacturer and distributor. SR SUNTOUR operates factories in Taiwan, China and Vietnam, with R&D and service offices collaborating throughout the world.

Our goal is to be the industry leader in value globally for prominent bicycle suspension components. We strive to produce the highest performing, most durable and reliable and the easiest to service bicycle and ebike suspension components. With roots tracing back to 1912 and SR SUNTOUR itself established in 1988 and continues to innovate and evolve to meet the needs of current bicycle riders and manufacturers.

## SOCIAL MEDIA / CONTACT

---



**SOCIAL MEDIA**  
CLICK TO VISIT  
SR SUNTOUR ONLINE



**CONTACT**  
CLICK TO CONTACT OUR  
WORLDWIDE DISTRIBUTORS



## SR SUNTOUR CORPORATE

---

### TAIWAN HEADQUARTER

SR SUNTOUR INC.  
#7 Hsing Yeh Rd.,  
Fu Hsing Industrial Zone, Chang Hua  
Taiwan 506027  
Tel. +886-4-7695115  
Fax. +886-4-7694028  
service@srsuntour.com.tw

### JAPAN

SR SUNTOUR JAPAN  
NR Bldg. 4F, 3-13-13  
Kuramae, Taito-ku,  
Tokyo 111-0051, Japan  
Tel. +81-(0)3-5829-9211  
Fax. +81-(0)3-5829-9241

### BELGIUM (EU)

SR SUNTOUR EUROPE S.A.  
Bld. Henri Rolin 5Bis  
1410 Waterloo Belgium  
Tel. +32-23544676  
Fax. +32-23547835  
Sales.sab@srsuntourcycling.com

### CHINA (SHEN ZHEN) SR

SUNTOUR SHEN ZHEN CO. LTD  
Suibei Industrial Zone, Suibei Rd.,  
Gongming Town, Guangming  
District, Shen Zhen, China Tel.  
+86-755-27105433 Fax. +86-

755-27105633 **CHINA (KUN  
SHAN) SR SUNTOUR KUN SHAN**  
CO. LTD 1500 Honghu Rd., Peng  
Lang, Kun Shan Development  
Zone, Jiang Su Province, China Tel.  
~~+86-512-5518-8088~~ Fax. ~~+86-~~  
512-5517-1117

### GERMANY (EU)

SR SUNTOUR EUROPE GMBH  
Riedstrasse 31  
83627 Warngau  
Germany  
Tel. +49-8021-50793-0  
Fax. +49-8021-50793-29  
service@srsuntour-cycling.com

### GERMANY (EU)

SR SUNTOUR DÜSSELDORF GMBH  
Fichtenstr. 115  
40233 Düsseldorf  
Germany  
Tel. +49-2115-42689-50  
Fax. +49-2115-42347-76

### USA

SR SUNTOUR NORTH AMERICA  
14511 NE 10th Avenue  
Vancouver WA 98685  
United States  
Tel. 360-737-6450  
service@srsuntourna.com

### USA

SR SUNTOUR SERVICE CENTER  
910 Watson Avenue  
Madison WI 53713  
United States  
Tel. 608-229-6610  
service@usulcorp.com

### VIETNAM SR SUNTOUR

VIETNAM CO. LTD Lot. 17-8,  
Street 3B, Protrade International  
Tech Park, An Tay Commune, Ben  
Cat Town, Binh Duong Province,  
Vietnam. Tel. +84-(0)274-3721-  
883 Tax Code: 3702401047

### FRANCE (EU)

SR SUNTOUR FRANCE SAS  
Alpespace  
604 Voie Galilée,  
73800 Sainte-Hélène-Du-Lac, France  
Tel. +33-4-85-86-00-99  
Fax. +33-4-79-28-69-71  
sav@srsuntour-cycling.com

### WWW.SRSUNTOUR.COM

Copyright © 2024 SR SUNTOUR inc. All rights reserved.  
Specifications are subject to change for improvement  
without notice.

