

NO.	DESCRIPTION	MATERIAL	QTY
1	TOP	AL-6061	1
2	LOCK OUT ADJUSTING SHAFT	AL-6061	1
3	ORIENTATION BALL	STEEL	2
4	ORIENTATION SPRING	STEEL	1
5	PIN	STEEL	1
6	LOCK OUT ADJUSTING MENT	AL-6061	1
7	AIR VALVE SET	AL-6061	1
8	O RING	NBR	1
9	O RING	NBR	1
10	O RING	NBR	1
11	MAIN SPINDLE	AL-7075	1
12	CONTROL ROD	AL-6061	1
13	O RING	NBR	2
14	E RING	STEEL	1
15	AC CONTROL PISTON	AL-6061	1
16	O RING	NBR	1
17	END PISTON	AL-6061	1
18	OIL SEAL SET	AL-7075	1
19	O RING	NBR	1
20	X RING	NBR	1
21	DU	STEEL	1
22	SCREW	STEEL	3
23	INSIDE BUMPER	NBR	1
24	WASHER	STEEL	1
25	SHIM	STEEL	1
26	SHIM	STEEL	1
27	TOP PISTON	AL-6061	1
28	TEFLON	TEFLON	1
29	O RING	NBR	1
30	SPUORRT SET	AL-6061	1
31	X RING	NBR	1
32	TEFLON	TEFLON	1
33	O RING	NBR	1
34	MAIN BODY	AL-6061	1
35	FLOATING PISTON	NI66	1
36	X RING	NBR	1
37	AIR BODY	AL-6061	1
38	X RING	NBR	1
39	TEFLON	TEFLON	1
40	DUST SEAL	NBR	1
41	SCREW	STEEL	1
42	O RING	NBR	1
43	DU	STEEL	2
44	AL BUSHING	AL-6061	2
45	AL BUSHING	AL-6061	2
46	STICKER		1
47			

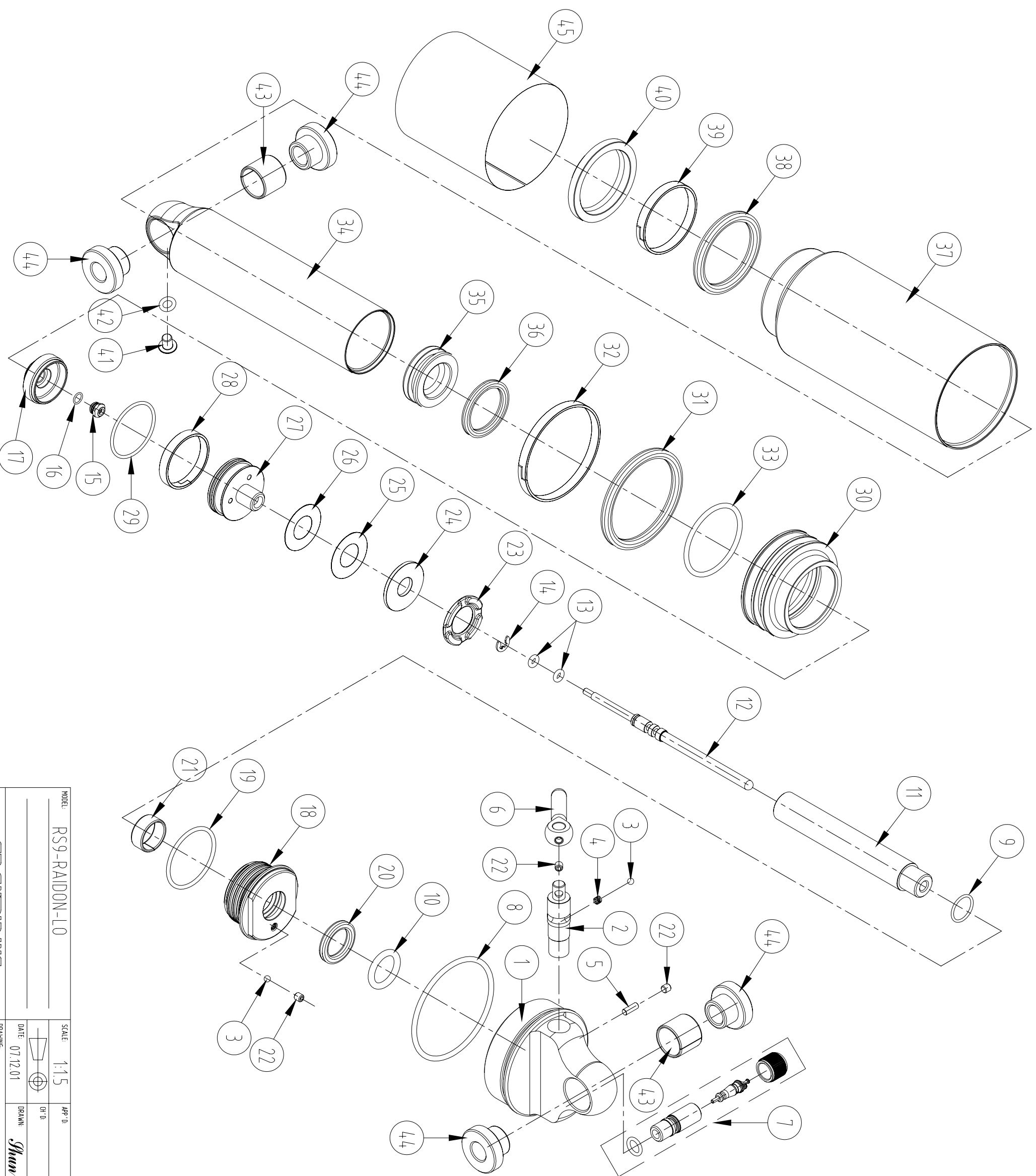

MODEL:	RS9-RAIDON-L0	SCALE:	1:1.5	APP'D:	
DATE:	07.12.01	DRAWN:	Shuu		
SFR SINTOUR INC.		DRAWING			